

Knot Wheel Brushes



Knot Wheel Brushes

Knot wheel brushes for grinders, angle grinders and stationary machines used in the preparation and reworking of bolt fillet and butt welds. They remove scale, rust, paint, slag, rubber residue and can be used for deburring.

All knots on our standard twisted wire wheel brushes are left hand twisted in order to minimize the undoing of the knots should the brush be used incorrectly. On request we can supply right hand twist brushes.

Knot Wheel Brushes with multiple Rows

Ready mounted brushes with multiple rows have a dense filling compared to single segment brushes, which are assembled together. In your order please state the width of the brush, bore size and type and thickness of wire.

We recommend to turn the brush during use in order to maintain sharpened wire ends.

On request other bores and wire diameter are available.

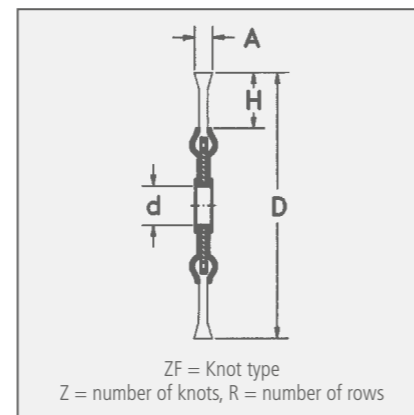

The listed knot wheel brushes are for the use in stationary machines.

Knot types ZF

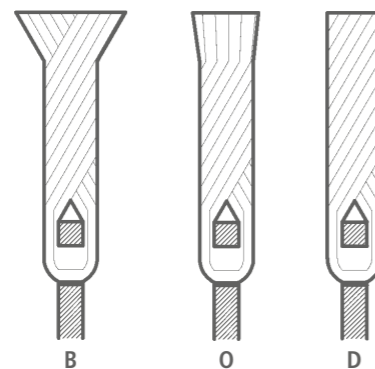

- B:** Rose Bud
- O:** Open Knot (wire ends are cut)
- D:** Fully knotted (wire ends are cut completely)

Stainless Steel Brushes

LESSMANN-brushes with stainless steel have green side plates. We use wire with material number 1.4310. Material number 1.4401 can be used on request.

Information on working on stainless steel you find at www.lessmann.com

Item Nos. in bold are available ex stock. Consider our minimum order value for *italic printed* article numbers (see page 139).

STH = steel wire, high tensile

ROH = stainless steel wire, high tensile



IIIIII
EAN

Knot Wheel Brushes, Steel Wire

D	A	d	H	Z	ZF	R	RPM	Pack.	STH 0.35 0.014"	STH 0.50 0.020"	STH 0.80 0.031"	left-right knotted
mm inch	mm inch	mm inch					max.		Art.-No.	Art.-No.	Art.-No.	Art.-No.
75 3	10 3/8	13 1/2	15	18	B	1	25,000	1	470.111	470.211*		
100 4	12 1/2	M 14 x 2,0	22	18	B	1	12,500	1	471.117*	471.217*		
115 4 1/2	14 1/2	22.2 7/8	24	20	B	1	12,500	1	472.111*	472.211*		472.211.WZ
115 4 1/2	14 1/2	M 14 x 2,0	24	20	B	1	12,500	1	472.117	472.217*		
125 5	14 1/2	22.2 7/8	29	20	B	1	12,500	1	473.111	473.211*		473.211.WZ
125 5	14 1/2	M 14 x 2,0	29	20	B	1	12,500	1	473.117	473.217		
150 6	14 1/2	22.2 7/8	32	26	B	1	12,500	1	474.111*	474.211	474.311	
150 6	14 1/2	M 14 x 2,0	32	26	B	1	12,500	1	474.117*	474.217	474.317	
178 7	14 1/2	22.2 7/8	38	32	B	1	12,500	1	475.111*	475.211*	475.311	
178 7	14 1/2	M 14 x 2,0	38	32	B	1	12,500	1	475.117*	475.217*	475.317	
200 8	14 1/2	22.2 7/8	41	36	B	1	9,000	1	476.111	476.211	476.311	
200 8	14 1/2	50.8 2	41	36	B	1	9,000	1		476.210.51	available on demand	
250 10	15 5/8	50.8 2**	42	52	O	1	5,000	1		477.210.75	477.310.75	
300 12	18 3/4	50.8 2**	56	58	O	1	5,000	1		478.210.75	478.310.75	

IIIIII
EAN

Knot Wheel Brushes, Stainless Steel Wire

D	A	d	H	Z	ZF	R	RPM	Pack.	ROH 0.35 0.014"	ROH 0.50 0.020"	left-right knotted
mm inch	mm inch	mm inch					max.		Art.-No.	Art.-No.	Art.-No.
75 3	10 3/8	13 1/2	15	18	B	1	20,000	1			
100 4	12 1/2	M 14 x 2,0	22	18	B	1	12,500	1		471.817*	
115 4 1/2	14 1/2	22.2 7/8	24	20	B	1	12,500	1	472.711*	472.811*	472.811.WZ
115 4 1/2	14 1/2	M 14 x 2,0	24	20	B	1	12,500	1	472.717*	472.817*	
125 5	14 1/2	22.2 7/8	29	20	B	1	12,500	1		473.811	473.811.WZ
125 5	14 1/2	M 14 x 2,0	29	20	B	1	12,500	1		473.817	
150 6	14 1/2	22.2 7/8	32	26	B	1	12,500	1		474.811	
150 6	14 1/2	M 14 x 2,0	32	26	B	1	12,500	1		474.817	
178 7	14 1/2	22.2 7/8	38	32	B	1	12,500	1		475.811*	
178 7	14 1/2	M 14 x 2,0	38	32	B	1	12,500	1		475.817	
200 8	14 1/2	22.2 7/8	41	36	B	1	9,000	1		476.811	

Thread 5/8 x 11 NC on request | * packed 25 pieces per carton | ** with turtle bore

Knot Wheel Brushes, multiple rows



IIIIII
EAN

Knot Wheel Brushes, multiple rows

D	A	EB	d Stand	d min	H	ZF	Z x R	RPM	Pack.	STH 0.35	STH 0.50	ROH 0.35	ROH 0.50
mm inch			mm inch					max.		0.014"	0.020"	0.014"	0.020"
100 4	22-24	12	20 3/4	10	21	B	20 x 2	12,500	1	471.12K	471.22K	471.72K	471.82K
100 4	30-32	18	20 3/4	10	21	B	20 x 3	12,500	1	471.13K	471.23K	471.73K	471.83K
100 4	34-36	25	20 3/4	10	21	B	20 x 4	12,500	1	471.14K	471.24K	471.74K	471.84K
115 4 1/2	22-24	18	30 1 1/4	10	23.5	B	22 x 2	12,500	1	472.12K	472.22K	472.72K	472.82K
115 4 1/2	30-32	25	30 1 1/4	10	23.5	B	22 x 3	12,500	1	472.13K	472.23K	472.73K	472.83K
115 4 1/2	34-36	30	30 1 1/4	10	23.5	B	22 x 4	12,500	1	472.14K	472.24K	472.74K	472.84K
125 5	22-24	18	30 1 1/4	13	28.5	B	24 x 2	12,500	1	473.12K	473.22K	473.72K	473.82K
125 5	30-32	25	30 1 1/4	13	28.5	B	24 x 3	12,500	1	473.13K	473.23K	473.73K	473.83K
125 5	34-36	30	30 1 1/4	13	28.5	B	24 x 4	12,500	1	473.14K	473.24K	473.74K	473.84K
150 6	22-24	18	30 1 1/4	13	31.5	O	28 x 2	12,500	1	474.12K	474.22K	474.72K	474.82K
150 6	30-32	25	30 1 1/4	13	31.5	O	28 x 3	12,500	1	474.13K	474.23K	474.73K	474.83K
150 6	36-38	30	30 1 1/4	13	31.5	O	28 x 4	12,500	1	474.14K	474.24K	474.74K	474.84K
178 7	22-24	18	50 2	16	37.5	O	34 x 2	12,500	1	475.12K	475.22K	475.72K	475.82K
178 7	30-32	25	50 2	16	37.5	O	34 x 3	12,500	1	475.13K	475.23K	475.73K	475.83K
178 7	36-38	30	50 2	16	37.5	O	34 x 4	12,500	1	475.14K	475.24K	475.74K	475.84K
200 8	22-24	18	50 2	16	41	O	38 x 2	9,000	1	476.12K	476.22K	476.72K	476.82K
200 8	30-32	25	50 2	16	41	O	38 x 3	9,000	1	476.13K	476.23K	476.73K	476.83K
200 8	36-38	30	50 2	16	41	O	38 x 4	9,000	1	476.14K	476.24K	476.74K	476.84K
250 10	26-30	18	100 4	20	42	O	52 x 2	5,000	1	477.12K	477.22K	477.72K	477.82K
250 10	38-40	26	100 4	20	42	O	52 x 3	5,000	1	477.13K	477.23K	477.73K	477.83K
250 10	50-54	34	100 4	20	42	O	52 x 4	5,000	1	477.14K	477.24K	477.74K	477.84K
300 12	26-30	18	100 4	30	56	O	58 x 2	5,000	1	478.12K	478.22K	478.72K	478.82K
300 12	38-40	26	100 4	30	56	O	58 x 3	5,000	1	478.13K	478.23K	478.73K	478.83K
300 12	50-54	34	100 4	30	56	O	58 x 4	5,000	1	478.14K	478.24K	478.74K	478.84K

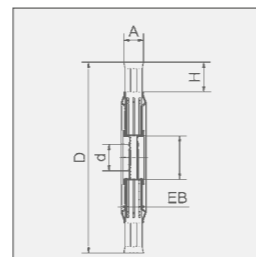

Joint Cleaning Brushes

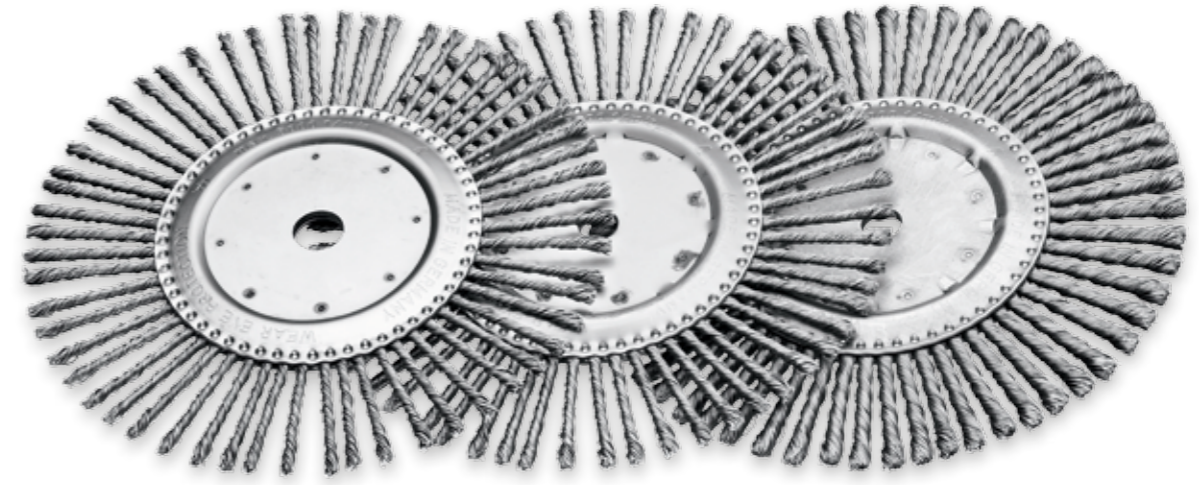

Joint Cleaning Brushes

D	A	d	H	Z	ZF	R	RPM	Pack.	STA 0.50 0.020"	STH 0.80 0.031"
mm inch	mm inch	mm inch					max.		Art.-No.	Art.-No.
300 12	6 1/4	20 3/4	67	64	D	1	5,000	5	478.200.06	478.300.06
300 12	8 5/16	20 3/4	67	64	D	1	5,000	5	478.200.08	478.300.08
300 12	10 3/8	20 3/4	67	64	D	1	5,000	5	478.200.10	478.300.10
300 12	6 1/4	25.4 1	67	64	D	1	5,000	5	478.225.06	478.325.06
300 12	8 5/16	25.4 1	67	64	D	1	5,000	5	478.225.08	478.325.08
300 12	10 3/8	25.4 1	67	64	D	1	5,000	5	478.225.10	478.325.10

Joint Cleaning Brushes

Joint cleaning brushes are used for the production of expansion joints in the construction of new linings as well as in restoration and repair. The application of this knot wheel brush is usually alike with all pavements.

When treating concrete and mastic asphalt joints, mainly knots with a tough wire without rose bud are used, because those knots show superb resistance.

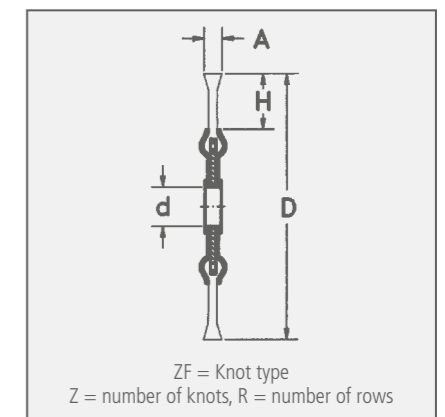

Item Nos. in bold are available ex stock. Consider our minimum order value for *italic printed* article numbers (see page 139).

STA = steel wire
STH = steel wire, high tensile
ROH = stainless steel wire, high tensile

Pipeline Brushes



Pipeline-Brushes

LESSMANN-Pipelinebrushes are specially developed for professional use on U- and V-welds in the pipeline industry.

The remarkable features of the high quality LESSMANN Pipeline Brushes are the long lifetime and the quietness of running. They are especially narrow and therefore they are the perfect tool for cleaning all welds at tube connections.

Pipeline Brushes, left-right knotted

Left-right knotted pipeline brushes usually are more aggressive, hence they are often used for heavy brushing operations. Besides the knots open less, therefore there are ideal for the treatment of edges.

Stainless Steel Brushes

LESSMANN-brushes with stainless steel wire have green side plates. We use wire with material number 1.4310. Material number 1.4401 can be used on request. Information on working on stainless steel you find at www.lessmann.com

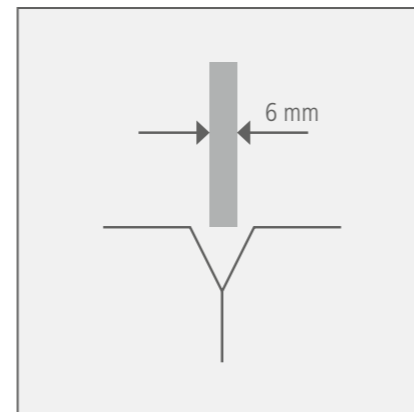
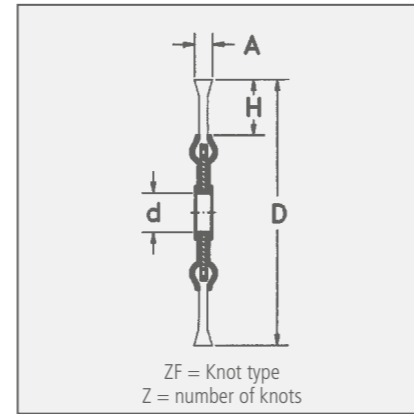

Item Nos. in bold are available ex stock.
Consider our minimum order value for *italic printed* article numbers (see page 139).
STH = steel wire, high tensile



Pipeline-Brushes, Steel Wire							Bo. 22.2 7/8"	M 14 x 2.0	W 5/8 x 11 NC
D	A	H	Z	ZF	RPM	Pack.*	STH 0.50 0.020"	STH 0.50 0.020"	STH 0.50 0.020"
mm inch	mm inch				max.		Art.-No.	Art.-No.	Art.-No.
100 4	6 1/4	19	28	D	20,000	10	available on demand	471.207.28	471.208.28
115 4 1/2	6 1/4	22	32	D	15,000	5/10	472.201.32	472.207.32	472.208.32
115 4 1/2	6 1/4	22	39	D	15,000	10	472.201.39	available on demand	available on demand
125 5	6 1/4	26	40	D	15,000	5/10	473.201.40	473.207.40	473.208.40
150 6	6 1/4	30	48	D	12,500	5/10	474.201.48	474.207.48	474.208.48
178 7	6 1/4	36	48	D	12,500	5/10	475.201.48	475.207.48	475.208.48
178 7	6 1/4	30	56	D	12,500	5/10	475.201.56	475.207.56	475.208.56
178 7	6 1/4	30	76	D	12,500	5/10	475.201.76	475.207.76	475.208.76

* Brushes with thread = packed 5 pieces per carton, brushes with bore = packed 10 pieces per carton

Pipeline-Brushes



Pipeline-Brushes, Stainless Steel							Bo. 22.2 7/8"	M 14 x 2.0	W 5/8 x 11 NC
D	A	H	Z	ZF	RPM	Pack.*	ROH 0.50 0.020"	ROH 0.50 0.020"	ROH 0.50 0.020"
mm inch	mm inch				max.		Art.-No.	Art.-No.	Art.-No.
100 2	6 1/4	19	28	D	20,000	5	available on demand	471.807.28	471.808.28
115 4 1/2	6 1/4	22	32	D	15,000	5/10	472.801.32	472.807.32	472.808.32
115 4 1/2	6 1/4	22	39	D	15,000	10	472.801.39	available on demand	available on demand
125 5	6 1/4	26	40	D	15,000	5/10	473.801.40	473.807.40	473.808.40
150 6	6 1/4	30	48	D	12,500	5/10	474.801.48	474.807.48	474.808.48
178 7	6 1/4	36	48	D	12,500	5/10	475.801.48	475.807.48	475.808.48
178 7	6 1/4	30	56	D	12,500	5/10	475.801.56	475.807.56	475.808.56
178 7	6 1/4	30	76	D	12,500	5/10	475.801.76	475.807.76	475.808.76

* Brushes with thread = packed 5 pieces per carton, brushes with bore = packed 10 pieces per carton

1 Pipeline Brushes, rose bud									STH 0.50 0.020"
D	A	d	H	Z	ZF	RPM	Pack.		Art.-No.
mm inch	mm inch	mm inch				max.			
178 7	6 1/4	22.2 7/8	28	76	B	12,500	10		475.2B1.76

2 Pipeline Brushes, left-right knotted									STH 0.50 0.020"
D	A	d	H	Z	ZF	RPM	Pack.		Art.-No.
mm inch	mm inch	mm inch				max.			
178 7	6 1/4	22.2 7/8	28	76	D	12,500	10		475.2W1.76

3 Pipeline Brushes, encapsulated									STM 0.35 0.014"
D	A	d	H			RPM	Pack.		Art.-No.
mm inch	mm inch	mm inch				max.			
150 6	6 1/4	22.2 7/8	29			9,000	10		300.771.KG
178 7	6 1/4	22.2 7/8	43			9,000	10		351.771.KG

Pipeline Brushes with rose bud

Knotted brushes with rose bud have a longer life time. They are used for a professional treatment of weld seams in the tube and pipeline construction.

Pipeline Brushes, left-right knotted

Left-right knotted pipeline brushes usually are more aggressive, hence they are often used for heavy brushing operations. Besides the knots open less, therefore there are ideal for the treatment of edges.

Pipeline Brushes, encapsulated

With encapsulated pipeline brushes a very exact and precise working is possible. By embedding in tough plastic the filling width always remains the same and early break of the wires can be prevented.

A working width of 6 mm still allows to reach U- and V- weld seams.

Item Nos. in bold are available ex stock. Consider our minimum order value for *italic printed* article numbers (see page 139).

STH = steel wire, high tensile

STM = brass coated steel

ROH = stainless steel wire, high tensile

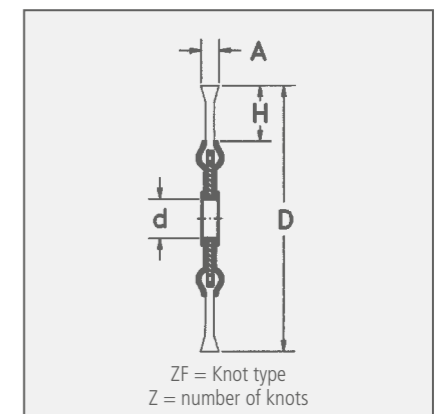

Single Segment Brushes



Single Segment Brushes

These brushes are mainly used for deburring purposes in stationary machines or processing centres.

The construction of these brushes allows it to assemble them to roller brushes of any desired width. Many different filling materials like steel, stainless steel or abrasive nylon with various grit are at your disposal.

Outstanding Processing

The flexible bristles align to the different shapes of working pieces.

An important advantage of the single segment brushes compared to other grinding tools, such as pads or grinding discs, is their gentle treatment.

Furthermore the brushes do not become encrusted. They are suitable for deburring work and fine polishing of stainless steel, light metal or plastic material. Besides the executions listed on this page other diameters and grit sizes are available.



Laser imprint of brushes

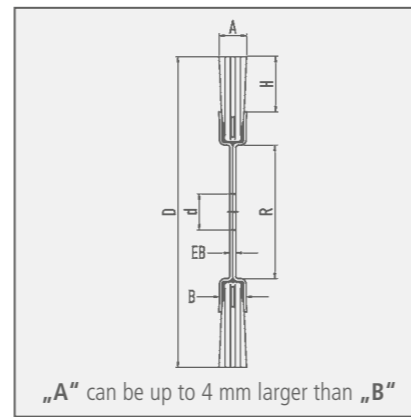

For further information on abrasive filaments please see page 13.

Item Nos. in bold are available ex stock. Consider our minimum order value for *italic printed* article numbers (see page 139).

SIC = silicon carbide bristles



1

2

1 Single Segment Wheel Brushes, Silicon Carbide Bristles

D	R	B	H	d Stand.	d	RPM	Pack.	SIC 80/1.2	SIC 120/1.1	SIC 120/0.6	SIC 180/1.0	SIC 320/0.6
mm inch				mm inch	min./max.	max.		Art.-No.	Art.-No.	Art.-No.	Art.-No.	Art.-No.
80 3 1/4	26	12	17	12 1/2	12-16	12,000	5		available on demand	310.841	310.851	310.871
100 2	30	12	21	12 1/2	12-20	8,000	5	320.821	available on demand	320.841	320.851	320.871
125 5	30	12	33	12 1/2	12-20	8,000	5	330.821	available on demand	330.841	330.851	330.871
150 6	50	14	32	12 1/2	12-30	6,000	5	340.821	340.831	340.841	340.851	340.871
178 7	50	14	46	12 1/2	12-30	6,000	5	350.821	350.831	350.841	350.851	350.871
178 7	60	16	43	12 1/2	12-40	6,000	5		available on demand	351.841	351.851	351.871
200 8	60	16	54	12 1/2	12-40	6,000	5		361.831	361.841	361.851	361.871
200 8	80	16	43	16 5/8	16-60	6,000	5		available on demand	362.841	362.851	362.871
200 8	100	16	33	16 5/8	16-80	6,000	5		360.831	360.841	360.851	360.871
250 10	100	16	58	16 5/8	16-80	6,000	5		available on demand	370.841	370.851	370.871
250 10	120	16	45	20 3/4	20-100	3,600	5		available on demand	371.841	371.851	371.871
250 10	150	19	30	25.4 1	25-130	3,600	5		372.831	372.841	372.851	372.871
300 12	120	16	70	20 3/4	20-100	3,600	5		available on demand	380.841	380.851	380.871
300 12	150	19	35	25.4 1	25-130	3,600	5		381.831	381.841	381.851	381.871

2 Single Segment Wheel Brushes, Silicon Carbide Bristles, 2 rows

D	R	B	H	d Stand.	d	RPM	Pack.	SIC 120/0.6	SIC 180/1.0	SIC 320/0.6
mm inch				mm inch	min./max.	max.		Art.-No.	Art.-No.	Art.-No.
200 8	80	27	43	16 5/8	16-60	6,000	5	available on demand	362.852	available on demand
250 10	100	27	58	16 5/8	16-80	6,000	5	available on demand	370.852	available on demand

Bore must be indicated in the order. Standard bore delivery ex stock, short termed. Other bores are available with extra charge: 1 - 10 pcs. EUR 5,00 / 11 - 25 pcs. EUR 3,00
R > 60 EB 3.0 mm / R < 60 EB 2.4 mm

Single Segment Wheel Brushes

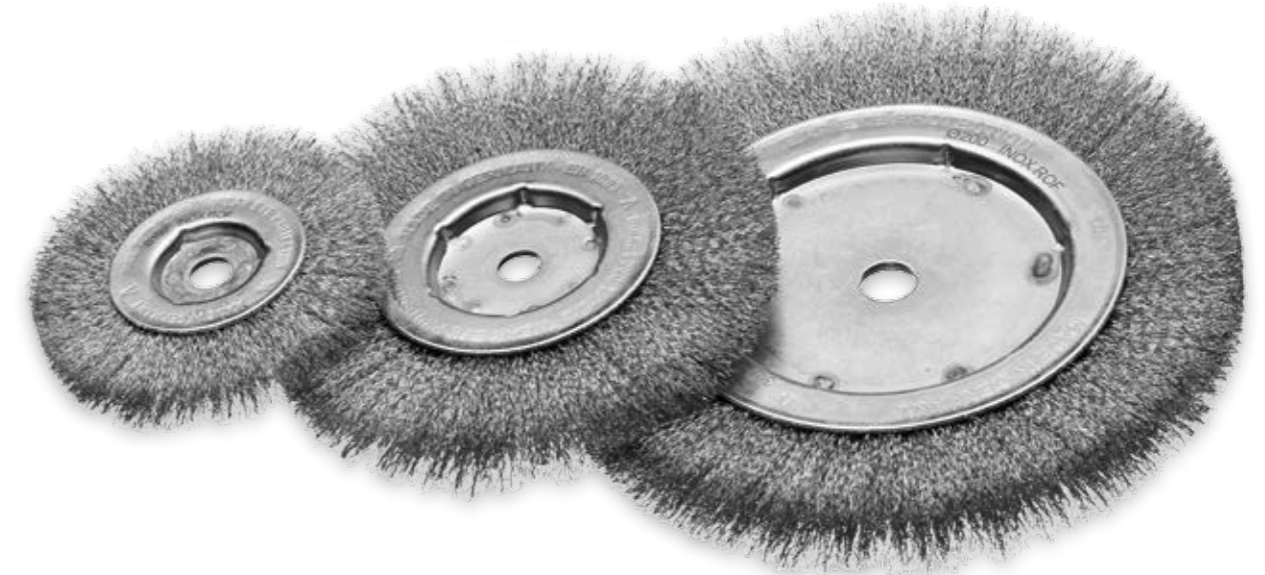

Single Segment Wheel Brushes, Steel Wire

D mm inch	R	B	H	d Stand. mm inch	d min./max.	RPM max.	Pack.	1			2		
								STA 0.20 0.008"	STA 0.30 0.012"	STL 0.35 0.014"	Art.-No.	Art.-No.	Art.-No.
80 3 1/4	26	12	17	12 1/2	12-16	12,000	5	310.141	310.161	available on demand			
100 4	30	12	21	12 1/2	12-20	8,000	5	320.141	320.161	320.707			
125 5	30	12	33	12 1/2	12-20	8,000	5	330.141	330.161	available on demand			
125 5	40	12	29	12 1/2	12-25	8,000	5	available on demand	331.161	available on demand			
150 6	50	14	32	12 1/2	12-30	6,000	5	340.141	340.161	340.707			
178 7	50	14	46	12 1/2	12-30	6,000	5	350.141	350.161	available on demand			
178 7	60	16	43	12 1/2	12-40	6,000	5	351.141	351.161	351.707			
200 8	60	16	54	12 1/2	12-40	6,000	5	361.141	361.161	available on demand			
200 8	80	16	43	16 5/8	16-60	6,000	5	362.141	362.161	362.707			
200 8	100	16	33	16 5/8	16-80	6,000	5	360.141	360.161	360.707			
250 10	100	16	58	16 5/8	16-80	6,000	5	370.141	370.161	available on demand			
250 10	120	16	45	20 3/4	20-100	3,600	5	371.141	371.161	available on demand			
300 12	120	16	70	20 3/4	20-100	3,600	5	380.141	380.161	available on demand			

Single Segment Wheel Brushes, Steel Wire, 2 rows

D mm inch	R	B	H	d Stand. mm inch	d min./max.	RPM max.	Pack.	STH 0.35 0.014"
								Art.-No.
200 8	80	27	43	16 5/8	16-60	6,000	5	362.272
250 10	100	27	58	16 5/8	16-80	6,000	5	370.272

Bore must be indicated in the order. Standard bore delivery ex stock, short termed. Other bores are available with extra charge: 1 - 10 pcs. EUR 5,00 / 11 - 25 pcs. EUR 3,00
R > 60 EB 3.0 mm / R < 60 EB 2.4 mm

Single Segment Wheel Brushes, Stainless Steel Wire

D mm inch	R	B	H	d Stand. mm inch	d min./max.	RPM max.	Pack.	ROF 0.20 0.008"		ROF 0.30 0.012"	
								Art.-No.	Art.-No.	Art.-No.	Art.-No.
80 3 1/4	26	12	17	12 1/2	12-16	12,000	5	310.341	310.361	310.361	310.361
100 2	30	12	21	12 1/2	12-20	8,000	5	320.341	320.361	320.361	320.361
125 5	30	12	33	12 1/2	12-20	8,000	5	330.341	330.361	330.361	330.361
125 5	40	12	29	12 1/2	12-25	8,000	5	available on demand	331.361	331.361	331.361
150 6	50	14	32	12 1/2	12-30	6,000	5	340.341	340.361	340.361	340.361
178 7	50	14	46	12 1/2	12-30	6,000	5	350.341	350.361	350.361	350.361
178 7	60	16	43	12 1/2	12-40	6,000	5	351.341	351.361	351.361	351.361
200 8	60	16	54	12 1/2	12-40	6,000	5	361.341	361.361	361.361	361.361
200 8	80	16	43	16 5/8	16-60	6,000	5	362.341	362.361	362.361	362.361
200 8	100	16	33	16 5/8	16-80	6,000	5	360.341	360.361	360.361	360.361
250 10	100	16	58	16 5/8	16-80	6,000	5	370.341	370.361	370.361	370.361
250 10	120	16	45	20 3/4	20-100	6,000	5	371.341	371.361	371.361	371.361
300 12	120	16	70	20 3/4	20-100	3,600	5	380.341	380.361	380.361	380.361

Bore must be indicated in the order. Standard bore delivery ex stock, short termed. Other bores are available with extra charge: 1 - 10 pcs. EUR 5,00 / 11 - 25 pcs. EUR 3,00
R > 60 EB 3.0 mm / R < 60 EB 2.4 mm

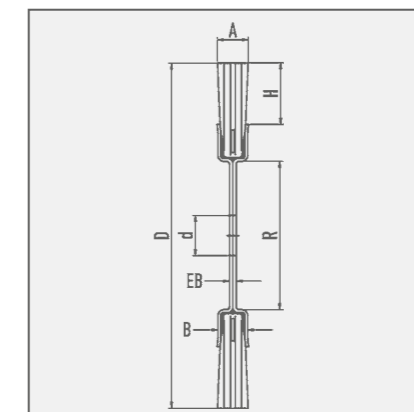

For further information on abrasive filaments please see page 13.
Item Nos. in bold are available ex stock.
Consider our minimum order value for *italic printed* article numbers (see page 139).

- STA = steel wire
- STH = steel wire, high tensile
- STL = cord wire, crimped
- ROF = stainless steel wire
- SIC = silicon carbide bristles

Wheel Brushes



Wheel Brushes

Wheel brushes filled with crimped wire are used for the purpose of obtaining different surface finishing:

- the removal of rust, paint and dirt
- for roughening, deburring, stripping or polishing.

Big or Small?

A decisive factor for choosing the most suitable brush is the wire and tube diameter. Brushes with a larger tube diameter (measure R) are filled with more wire, are more aggressive and have a longer life.

In our catalogue are the usual tube diameters – other diameters can also be supplied. More technical instruction such as peripheral speed etc. see pages 8 - 10.

The bore must be indicated in the order. Without any instruction delivery will be with standard bore "d Stand".

Stainless Steel Brushes

Information on working on stainless steel you find at www.lessmann.com

Other filling materials, filling diameters and special executions

Take advantage of the LESSMANN range of products, of the experience in developing and producing brushes! We are able to produce special executions on demand.

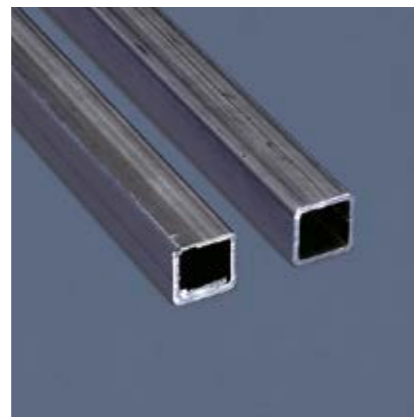

Item Nos. in bold are available ex stock. Consider our minimum order value for *italic printed* article numbers (see page 139).

STA = steel wire

STM = brass coated steel

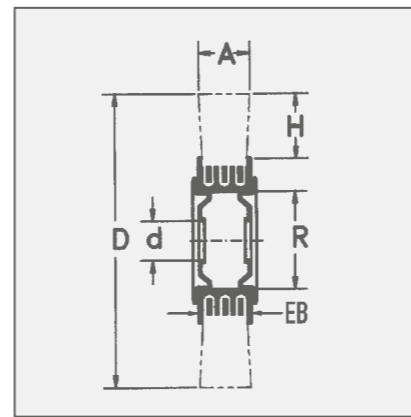

Adapter Set

All brushes are supplied with adapter sets for easy mounting on all popular grinding machines. The adapters have the following dimensions:

Set 1 / tube 30:

30 / 1" / 22.2 / 20 / 16 / 1/2" / 12

Set 2 / tube 40:

40 / 3/2" / 22.2 / 20 / 16 / 1/2"

Set 3 / tube 50:

50 / 3/2" / 22.2 / 20 / 16 / 1/2"

Set 4 / tube 80 + 100:

brushes with metal discs, bore 50.8 and double keyway 7x13; plus adapter to bore 30.

Set 5 / tube 80 + 100:

brushes with metal discs, bore 50.8 and double keyway 7x13; plus adapter to bore 32.

By usage without adapter set the actual size might be up to 0.2 mm below nominal size.



1

2

IIIIII
EAN

Wheel Brushes, Steel Wire

D	A	EB	R	H	d Stand.	d	RPM	Pack.	1		2
									STA 0.15 0.006"	STA 0.20 0.008"	STM 0.30 0.012"
80 3 1/4	18-20	18	20	20	10 3/8	10-20	10,000	1	available on demand	312.142	312.162
80 3 1/4	25-27	24	20	20	10 3/8	10-20	10,000	1	available on demand	312.143	312.163
100 2	20-22	19	30	23	Set 1	10-30	8,000	1	323.132	323.142	323.162
100 2	28-30	25	30	23	Set 1	10-30	8,000	1	323.133	323.143	323.163
125 5	21-23	20	40	27	Set 2	13-40	6,000	1	334.132	334.142	334.162
125 5	29-31	26	40	27	Set 2	13-40	6,000	1	available on demand	334.143	334.163
150 6	22-24	20	40	33	Set 2	13-40	6,000	1	344.132	344.142	344.172*
150 6	30-34	26	40	33	Set 2	13-40	6,000	1	344.133	344.143	344.173*
150 6	23-25	22	50	33	Set 3	13-50	6,000	1	345.132	345.142	345.162
150 6	30-34	29	50	33	Set 3	13-50	6,000	1	345.133	345.143	345.163
178 7	23-26	22	50	37	Set 3	16-50	6,000	1	available on demand	355.142	355.162
178 7	32-35	29	50	37	Set 3	16-50	6,000	1	355.133	355.143	355.163
200 8	24-27	22	50	48	Set 3	16-50	6,000	1	365.132	365.142	365.172*
200 8	35-38	29	50	48	Set 3	16-50	6,000	1	365.133	365.143	365.173*
200 8	28-32	25	80	38	Set 4+1	16-80	4,500	1	available on demand	366.142	366.162
200 8	40-45	33	80	38	Set 4+1	16-80	4,500	1	available on demand	366.143	366.163
250 10	30-35	25	80	50	Set 4+1	20-80	3,600	1	available on demand	376.142	376.162
250 10	42-45	33	80	50	Set 4+1	20-80	3,600	1	available on demand	available on demand	376.163
250 10	32-37	26	100	50	Set 4+1	20-100	3,600	1	available on demand	377.142	377.162
250 10	43-48	35	100	50	Set 4+1	20-100	3,600	1	available on demand	377.143	377.163
250 10	55-60	45	100	50	Set 4+1	20-100	3,600	1	available on demand	377.144	377.164
300 12	35-40	26	100	60	Set 4	30-100	3,000	1	available on demand	387.142	387.162
300 12	47-52	35	100	60	Set 4	30-100	3,000	1	available on demand	387.143	387.163
350 14	35-40	26	100	85	Set 5	32-100	2,400	1	available on demand	397.142	397.172*
350 14	55-60	35	100	85	Set 5	32-100	2,400	1	available on demand	397.143	397.173*

Bore must be indicated in the order. Standard bore delivery ex stock, short termed. Other bores are available with extra charge: 1 - 10 pcs. EUR 5.00 / 11 - 25 pcs. EUR 3.00

Wheel Brushes



WHEEL BRUSHES

IIIIII
EAN

Wheel Brushes, Stainless Steel

D mm inch	A	EB	R	H	d Stand. mm inch	d min./max.	RPM max.	Pack.	ROF 0.20 0.008"	
									Art.-No.	Art.-No.
80 3 1/4	18-20	18	20	20	10 3/8	10-20	10,000	1	312.342	312.362
80 3 1/4	25-27	24	20	20	10 3/8	10-20	10,000	1	available on demand	312.363
100 4	20-22	19	30	23	Set 1	10-30	8,000	1	323.342	323.362
100 4	28-30	25	30	23	Set 1	10-30	8,000	1	323.343	323.363
125 5	21-23	20	40	27	Set 2	13-40	6,000	1	334.342	334.362
125 5	29-31	26	40	27	Set 2	13-40	6,000	1	334.343	334.363
150 6	22-24	20	40	33	Set 2	13-40	6,000	1	344.342	344.362
150 6	30-34	26	40	33	Set 2	13-40	6,000	1	available on demand	344.363
150 6	23-25	22	50	33	Set 3	13-50	6,000	1	345.342	345.362
150 6	30-34	29	50	33	Set 3	13-50	6,000	1	345.343	345.363
178 7	23-26	22	50	37	Set 3	16-50	6,000	1	355.342	355.362
178 7	32-35	29	50	37	Set 3	16-50	6,000	1	available on demand	355.363
200 8	24-27	22	50	48	Set 3	16-50	6,000	1	365.342	365.362
200 8	35-38	29	50	48	Set 3	16-50	6,000	1	365.343	365.363
200 8	28-32	25	80	38	Set 4+1	16-80	4,500	1	366.342	366.362
200 8	40-45	33	80	38	Set 4+1	16-80	4,500	1	366.343	366.363
250 10	30-35	25	80	50	Set 4+1	20-80	3,600	1	376.342	376.362
250 10	42-45	33	80	50	Set 4+1	20-80	3,600	1	376.343	376.363
250 10	32-37	26	100	50	Set 4+1	20-100	3,600	1	377.342	377.362
250 10	43-48	35	100	50	Set 4+1	20-100	3,600	1	377.343	377.363
300 12	35-40	26	100	60	Set 4	30-100	3,000	1	387.342	387.362
300 12	47-52	35	100	60	Set 4	30-100	3,000	1	387.343	387.363
350 14	35-40	26	100	85	Set 5	32-100	2,400	1	available on demand	397.362

Bore must be indicated in the order. Standard bore delivery ex stock, short termed. Other bores are available with extra charge: 1 - 10 pcs. EUR 5.00 / 11 - 25 pcs. EUR 3.00

IIIIII
EAN

Wheel Brushes, Brass Wire

D mm inch	A	EB	R	H	d Stand. mm inch	d min./max.	RPM max.	Pack.	MES 0.20 0.008"	
									Art.-No.	Art.-No.
80 3 1/4	18-20	18	20	20	10 3/8	10-20	10,000	1	312.542	312.562
80 3 1/4	25-27	24	20	20	10 3/8	10-20	10,000	1	312.543	312.563
100 4	20-22	19	30	23	Set 1	10-30	8,000	1	323.542	323.562
100 4	28-30	25	30	23	Set 1	10-30	8,000	1	323.543	323.563
125 5	21-23	20	40	27	Set 2	13-40	6,000	1	334.542	334.562
125 5	29-31	26	40	27	Set 2	13-40	6,000	1	334.543	available on demand
150 6	22-24	20	40	33	Set 2	13-40	6,000	1	344.542	344.562
150 6	30-32	26	40	33	Set 2	13-40	6,000	1	344.543	344.563
150 6	23-25	22	50	33	Set 3	13-50	6,000	1	345.542	345.562
150 6	30-34	29	50	33	Set 3	13-50	6,000	1	345.543	345.563
178 7	23-26	22	50	37	Set 3	16-50	6,000	1	355.542	355.562
178 7	32-35	29	50	37	Set 3	16-50	6,000	1	355.543	355.563
200 8	24-27	22	50	48	Set 3	16-50	6,000	1	365.542	365.562
200 8	35-38	29	50	48	Set 3	16-50	6,000	1	365.543	365.563
200 8	28-32	25	80	38	Set 4+1	16-80	4,500	1	366.542	366.562
200 8	40-45	33	80	38	Set 4+1	16-80	4,500	1	366.543	366.563
250 10	30-35	25	80	50	Set 4+1	20-80	3,600	1	376.542	376.562
250 10	42-45	33	80	50	Set 4+1	20-80	3,600	1	available on demand	available on demand
250 10	32-37	26	100	50	Set 4+1	20-100	3,600	1	available on demand	377.562
250 10	43-48	35	100	50	Set 4+1	20-100	3,600	1	available on demand	available on demand
300 12	35-40	26	100	60	Set 4	30-100	3,000	1	available on demand	387.562
300 12	47-52	35	100	60	Set 4	30-100	3,000	1	available on demand	available on demand
350 14	35-40	26	100	85	Set 5	32-100	2,400	1	available on demand	397.562

Bore must be indicated in the order. Standard bore delivery ex stock, short termed. Other bores are available with extra charge: 1 - 10 pcs. EUR 5.00 / 11 - 25 pcs. EUR 3.00

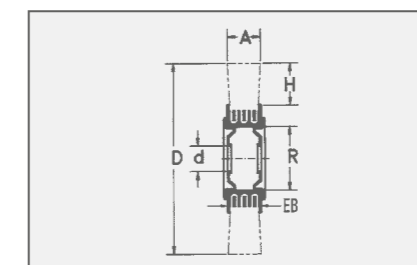

Item Nos. in bold are available ex stock. Consider our minimum order value for *italic printed* article numbers (see page 139).

ROF = stainless steel wire

MES = brass wire

Brushes for the wood machining industry



Satin Brushes

Satin brushes are the perfect tool for satining, polishing, abrading/smoothing, matting and structuring.

Staple Set Wheel and Disc Brushes

Wheel and Disc Brushes with abrasive nylon filament are used for the wood machining industry. Used on angle grinders, the disc brushes are ideal for maintaining, cleaning, structuring or polishing wood.

Besides the brushes are used for giving wood a rustic effect or for roughening it before treating with colour or lacquer.

The brushes are very effective when working on large surfaces.

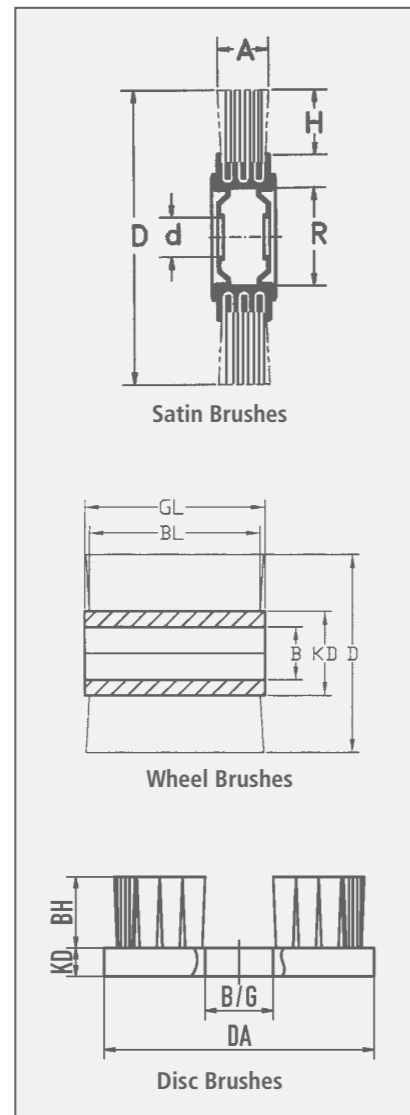

Item Nos. in bold are available ex stock. Consider our minimum order value for *italic printed* article numbers (see page 139).

STM = brass coated steel

STL = cord wire, crimped

ROF = stainless steel wire

SIC = silicon carbide bristles



IIIIII
EAN

Satin Brushes										
	D	A	H	d	RPM	Pack.	ROF 0.20 0.008"	STM 0.35 0.014"	STL 0.25 0.010"	
	mm inch	mm inch		mm inch	max.		Art.-No.	Art.-No.	Art.-No.	
1	100 4	12 1/2	21	19.2 3/4	8,000	5	320.341.19	320.821.19	320.703.19	
2	100 4	70 2 3/4	23	19.2 3/4	8,000	1	323.348.19	323.828.19	323.704.19	
	100 4	100 4	23	19.2 3/4	8,000	1	323.305.19	323.805.19	323.705.19	
	D	A	H	d	RPM	Pack.	STM 0,35 0.014"	SIC 60/1.5	SIC 80/1.2	SIC K 120/1.1
	mm inch	mm inch		mm inch	max.		Art.-No.	Art.-No.	Art.-No.	Art.-No.
2	100 4	120 4 3/4	21	12.7 1/2	8,000	1	323.770.13	323.810.13	323.820.13	323.830.13

Bore must be indicated in the order. Standard bore delivery ex stock, short termed. Other bores are available with extra charge: 1 - 10 pcs. EUR 5.00 / 11 - 25 pcs. EUR 3.00

3 Staple Set Wheel Brushes											
	D	GL	BL	B	KD	RPM	Pack.	SIC 46/1.6	SIC 60/1.5	SIC 80/1.2	SIC 120/1.10
	mm inch					max.		Art.-No.	Art.-No.	Art.-No.	Art.-No.
	140 5 1/2	58	40	M 14	80	2,500	1	402.881	402.882	402.880	402.883
	140 5 1/2	90	75	M 14	80	2,500	1	402.891	402.892	402.890	402.893

4 Staple Set Disc Brushes							
Filling	DA mm inch	KD mm inch	BH	B/O	RPM max.	Pack.	Art.-No.
SIC 46/1.6	130 5 1/8	20 3/4	50 2	M 14	2,500	1	405.843
SIC 60/1.5	130 5 1/8	20 3/4	50 2	M 14	2,500	1	405.844
SIC 80/1.2	130 5 1/8	20 3/4	50 2	M 14	2,500	1	405.845

Special Models



Band Saw Brushes

Wheel Brushes in circular saws or band saws are used for cleaning the chipping space. A wheel brush with diameter 80-100 mm is pressed against the saw blade (circular or band saw). By moving the saw blade or band the brush is rolling and it taking the chipping out of the shipping space. Hence a built-up edge is prevented and the durability of the saw blade extended. The used wheel brushes usually are with steel wire, corded wire or nylon filament. The brushes are suitable for all common machines.

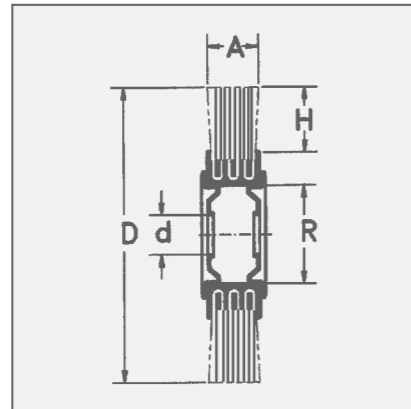

Item Nos. in **bold** are available ex stock. Consider our minimum order value for *italic printed* article numbers (see page 139).

STA	= steel wire
STM	= brass coated steel
STL	= cord wire, crimped
PA	= polyamide

Stripping Brushes

For the removal of laquer and other insulations from cables and electric equipment. The polished surface and the concentric running enable soft removal of laquer from the wires.

Stainless Steel Brushes

Information on working on stainless steel you find at www.lessmann.com



Band Saw Brushes

	Filling	D mm inch	A mm inch	H	d mm inch	RPM max.	Pack.	Art.-No.
1	PA 0.50 0.020"	85 3 1/4	10 3/8	14	12 1/2	8,000	10	<i>300.091</i>
	PA 0.50 0.020"	100 4	13 1/2	21	12 1/2	8,000	10	320.001
	PA 0.50 0.020"	100 4	13 1/2	21	13 1/2	8,000	10	320.004
	PA 0.80	100 4	20-22 3/4	23	12 1/2	8,000	10	<i>323.002</i>
	PA 0.80	100 4	13 1/2	21	12 1/2	8,000	10	<i>320.003</i>
2	STA 0.20 0.008"	80 3 1/4	12 1/2	20	10 3/8	15,000	10	<i>312.141</i>
	STA 0.35 0.014"	100 4	13 1/2	21	12 1/2	4,500	10	320.161.12
3	STM 0.20 0.008"	60 2 3/8	10-12 3/8	19	6 1/4	15,000	10	<i>300.742</i>
	STM 0.20 0.008"	80 3 1/4	15 5/8	27	6.8 1/4	15,000	10	<i>311.742.01</i>
	STM 0.30 0.012"	80 3 1/4	15 5/8	27	8 5/16	15,000	10	311.762
	STL 4 x 0.25 0.010"	80 3 1/4	18-20 3/4	27	6 1/4	15,000	10	310.702.06

Stripping Brushes

D	A	d	Pack.	STA 0.10 0.004"	STA 0.15 0.006"	STA 0.20 0.008"	STA 0.25 0.010"	STA 0.30 0.012"
mm inch	mm inch	mm inch		Art.-No.	Art.-No.	Art.-No.	Art.-No.	Art.-No.
30 1 1/4	20 3/4	6 1/4	10	<i>301.213.10</i>	<i>301.213.15</i>	<i>301.213.20</i>		<i>301.213.30</i>
35 1 1/2	20 3/4	6 1/4	10		<i>301.214.15</i>	<i>301.214.20</i>	available on demand	<i>301.214.30</i>
40 1 3/8	25 1	10 3/8	10		<i>301.225.15</i>	<i>301.225.20</i>	<i>301.225.25</i>	<i>301.225.30</i>
80 3	30 1 1/4	16 5/8	10			<i>301.236.20</i>	available on demand	<i>301.236.30</i>

Accessories



Adapters
With these adapters the bore can be reduced to the required size.

The wheel brushes are supplied with adapter sets which makes it possible to mount the brushes on all popular grinding machines. The adapters have the following dimensions:

- Set 1 / tube 30**
30 / 1" / 22,2 / 20 / 16 / 1/2" / 12
- Set 2 / tube 40:**
40 / 32 / 1" / 22,2 / 20 / 16 / 1/2"
- Set 3 / tube 50:**
50 / 32 / 1" / 22,2 / 20 / 16 / 1/2"
- Set 4 / tube 80 + 100:**
brushes with metal discs, bore 50.8 and double keyway 7x13; plus adapter to bore 30. Further reduction possible with set 1.
- Set 5 / tube 80 + 100:**
brushes with metal discs, bore 50.8 and double keyway 7x13; plus adapter to bore 32. Further reduction possible with set 1.

Drive Arbors
For use on drilling machines.

Metal Discs
Brushes with tube diameter 80 and 100 mm are supplied with our standard metal plates made of steel. Occasionally these metal plates are also required for brushes with smaller tubes. The metal plates on this page are therefore also suitable for the brushes on page 29 - 31. Please indicate the required bore size on your order and note that normally two metal plates are required for one brush.

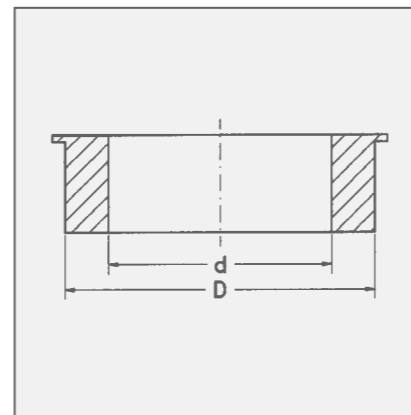

Item Nos. in bold are available ex stock. Consider our minimum order value for *italic printed* article numbers (see page 139).

A technical advice and safety information leaflet is included.

The practical adapter sets can also be ordered separately.

Single plastic reducing rings in many different dimensions can be supplied ex stock.



Adapter Sets		D	d	Pack.	Art.-No.
1	Set 1 Tube 30	30	1" - 22.2 - 20 - 16 - 1/2" - 12	2	000.886.63
2	Set 2 Tube 40	40	32 - 1" - 22.2 - 20 - 16 - 1/2"	2	000.886.64
3	Set 3 Tube 50	50	32 - 1" - 22.2 - 20 - 16 - 1/2"	2	000.886.65
4	Set 4 Tube 80/100	50.8	30 (further adapters with Set 1)	2	000.886.68
5	Set 5 Tube 80/100	50.8	32	2	000.888.32
5 Single plastic reducing rings in many different dimensions can be supplied ex stock.					

Drive Arbors		6		7			
D mm inch	L mm inch	Thread	Art.-No.	D mm inch	L mm inch	Thread	Art.-No.
6 1/4	60 2 3/8	M 10 x 1,5	000.041	6 1/4	40 1 3/8	M 10 left	000.044
10 3/8	60 2 3/8	M 10 x 1,5	000.042	6 1/4	50 2	M 12 left	000.045
10 3/8	75 3	M 14 x 2,0	000.043				

8 Metal Discs as Spare Part		Art.-No.		Art.-No.		Art.-No.		Art.-No.	
R 30	000.631	R 40	000.641	R 50	000.651	R 80	000.661	R100*	000.671

9 Thread Adapter		L mm inch		Pack.	Art.-No.
from	to				
Internal W 1/2	Internal M 12	40	1 3/8	1	001.211
Internal W 1/2	Internal M 10	40	1 3/8	1	001.212
Internal W 3/8	Internal M 10	40	1 3/8	1	001.215
External M 10	Internal W 1/2	40	1 3/8	1	001.222
External M 10	Internal W 3/8	40	1 3/8	1	001.225

Bore must be indicated!
* On request with double keyset 12 x 7 (50.8 / 52.9 / 54.5)