

# DeZURIK BAW AWWA BUTTERFLY VALVES

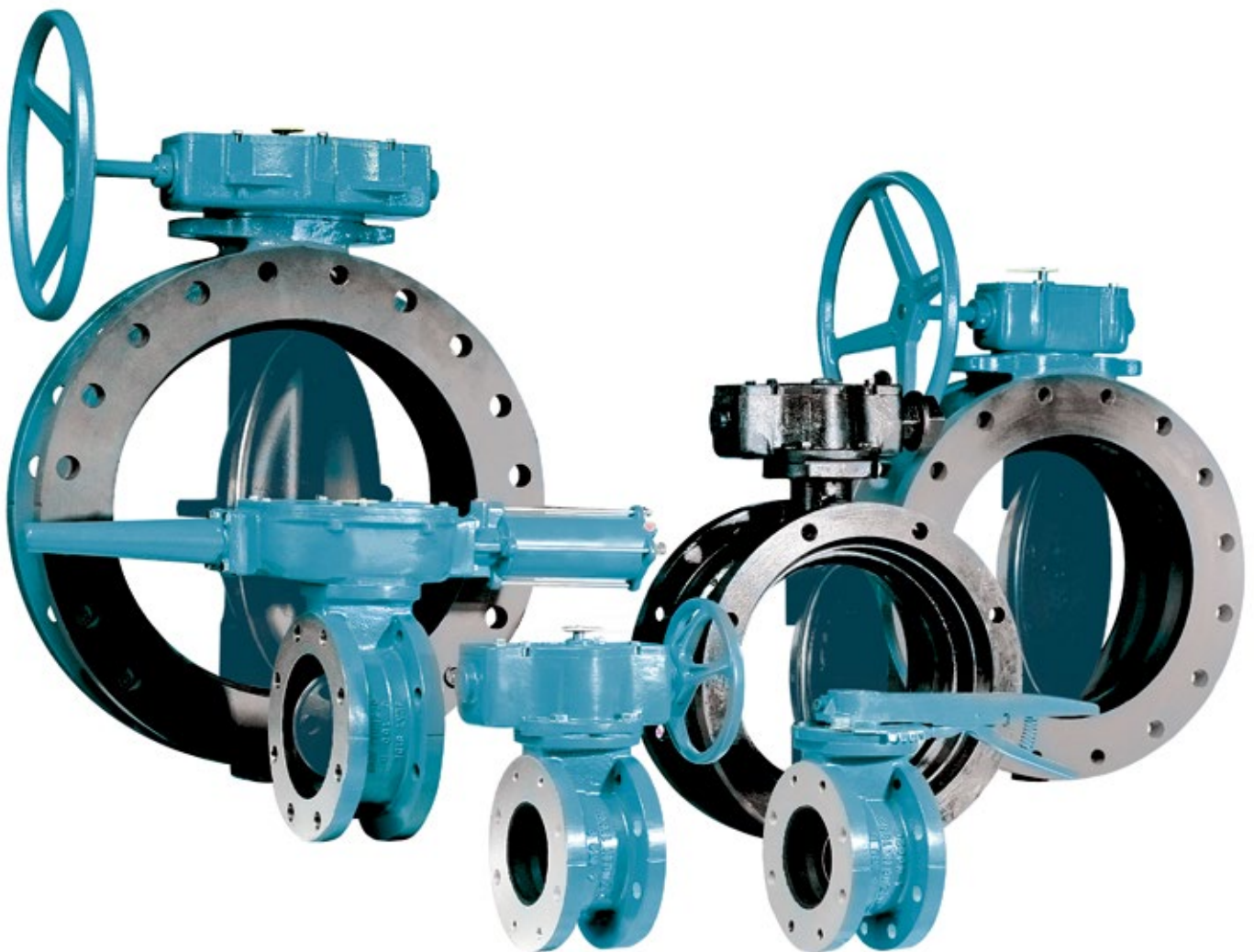

# Defining the DeZURIK Difference



## DeZURIK History

DeZURIK is an innovative global leader for the water and wastewater treatment industries, recognized worldwide for high quality and superior performance.

While DeZURIK provides innovative valves and related equipment for water and wastewater, DeZURIK eagerly responds as new industries develop and existing industries progress. Our knowledgeable engineers are quick to respond with groundbreaking technological advances. They continue to develop a wide range of products focusing on water and wastewater treatment, pulp and paper, chemical and petrochemical, power, mining and other process industries. Some of our products increase accuracy. Others assure durability or reliability. All of our products work to enhance our customer's profitability.

## Certification

For our latest certifications, please visit our web site [www.dezurik.com](http://www.dezurik.com).

## Leading Edge Design Software

Computer Aided Design systems are used by research and development engineers throughout the product development cycle. DeZURIK utilizes leading edge solid modeling software which allows product designers to view valve parts and assemblies three dimensionally. The 3D models are electronically transferred to Finite Element Analysis software where stress and deflection calculations are performed. This software allows designers to visualize deflection of critical parts under extreme loads. Proper relief and safety factors are included in every valve design to ensure long performance life.

## Advanced Machining Capabilities

DeZURIK's solid modeling CAD software allows parts to be directly transferred to CAM modules for machine fixture design and NC programming. AWWA Butterfly Valves are manufactured with the most sophisticated machining centers available. Milling, drilling, boring, and tapping operations are performed on fully automated machine centers that perform sequential, error-free operations. DeZURIK's investment in state-of-the-art machining centers ensures products of consistently high quality.

## Rubber & Elastomer Compounding

DeZURIK formulates and handcrafts rubber to control quality on critical components. Over 50 years of pressure/temperature rubber-molding experience assures the AWWA seat design provides long, maintenance-free service. DeZURIK compounds its own resilient seat materials to assure low operating torque and protection from pipeline corrosion and abrasion from sedimentation deposits.

## Prototype Design Testing

Valve prototypes of sizes up to 36" (900mm) are tested in DeZURIK's flow laboratory. Flow ranges from a few cubic centimeters per minute to 72,000 gallons per minute can be tested. Computer controlled testing automatically sets flow, monitors temperatures, takes sample readings, and analyzes information. Before release, beta test sites are used to gain actual field experience. Valves are tested up to 10,000 cycles per AWWA C504 specifications. Proof of design testing certification is available.



## Applications

DeZURIK AWWA Butterfly Valves are designed for applications throughout water and wastewater treatment plants, water distribution systems, power plants, and industrial plants. AWWA Butterfly Valves can be applied in applications demanding high-quality and thoroughly tested valves which offer many years of trouble-free service.



## Pump Check Control Systems

Pump check control systems, utilizing AWWA Butterfly Valves, are available in many different models.



## Production Testing

Each valve is given a hydrostatic, seat leakage and performance test per AWWA C504 before it is shipped.

# 3-20" (80-500mm) Design

## Features for Years of Trouble-Free Service

### Body Styles

Flanged, ASME B16.1 Class 125,  
3-20" (80-500mm), Valve Class 150B

Flanged, ASME B16.1 Class 125,  
3-20" (80-500mm), Valve Class 250B

Flanged, ASME B16.1 Class 250,  
3-18" (80mm-450mm), Valve Class 250B

Mechanical Joint, ANSI/AWWA C111/A21.11, 4-20"  
(100-500mm), Valve Class 150B

Mechanical Joint, ANSI/AWWA C111/A21.11, 4-20"  
(100-500mm), Valve Class 250B

### Corrosion Resistant Shaft

Stainless steel shafts provide corrosion resistance in bearing and packing journal areas to ensure long bearing and packing life. Standard shaft materials include 304, 316, and 17-4 PH stainless steel.

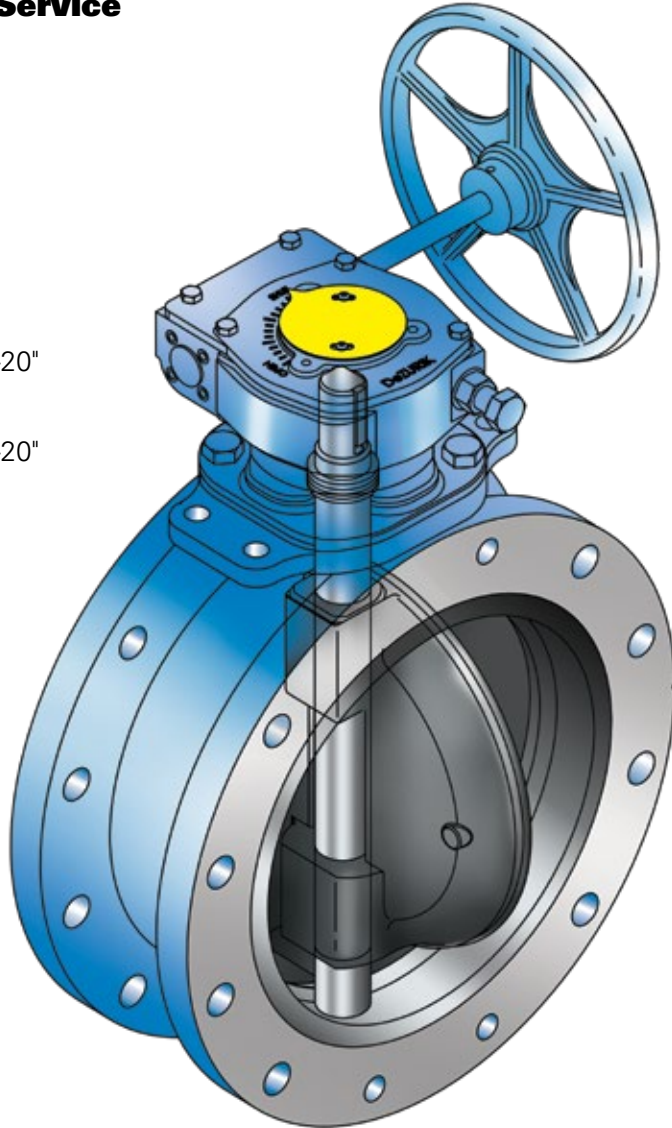

### Self-Compensating Shaft Seals

Shaft seals are self-compensating, V-type packing. DeZURIK uses a minimum of four sealing rings. This proven multi-ring sealing technology offers reliability and continuous self-adjustment.

### Long Life, Low Friction Bearings

Upper and lower journal shaft bearings are designed to provide high compressive strength, low friction and require no lubrication.



## 3-20" (80-500mm) Design

---

### Fully Rubber Lined Body

A fully rubber lined body is standard, eliminating the need for inner body coating, and protecting the body against corrosion buildup.

### Integrity of the Proven Molding Process

The rubber bonding process used on DeZURIK AWWA Butterfly Valves is proven by more than 50 years of field experience. AWWA C504 requires testing of the bonding process per ASTM D429, method B. The test requires a 1" (25mm) wide strip of rubber to withstand a minimum 75 lbs. pull force (at a 90° angle) before tearing away from the valve body. During destructive testing, the rubber must tear before the bond between the rubber seat and metal valve body gives way, demonstrating that the bond is stronger than the rubber. Based on extensive experience and proof of design testing, DeZURIK can assure that a molded-in body seat remains maintenance-free for the life of the valve.

### Choice of Seat Materials

Standard seat materials include Acrylonitrile-Butadiene (NBR) for water service and EPDM for high-temperature applications such as air blower lines.

### 4° Sealing Surface

The spherical sealing surface, molded into the valve seat, provides constant interference between the sealing surface and the disc edge for a full 4° sealing range. This allows the actuator to be adjusted within the correct sealing range while the valve is under pressure and flow.

### Molded-In Body Seat

The pressure/temperature molding process used on AWWA Butterfly Valves provides a long-lasting, maintenance-free seat. DeZURIK's molded-in body seat lasts far beyond the 10,000 cycles required by AWWA C504. The molded seat-in-body design provides:

- Uniform rubber thickness.
- Consistent interference between the rubber seating surfaces and the stainless steel disc edge.
- Tight tolerance control on critical seat dimensions.



## 3-20" (80-500mm) Design

---



### **Disc Locators**

An innovative, molded-in, disc-centering device aligns the disc in the seat, providing a positive seal and longer seat life. Disc hubs, supported by the locators, ensure disc location accuracy. The offset style disc design means disc-alignment locators are separate from the sealing surface, extending valve seat life.

### **Proven Disc-To-Shaft Pinning**

All DeZURIK disc-to-shaft pinning connections conform to AWWA C504. Disc-to-shaft pinning is provided by a stainless steel torque screw on sizes 3-12" (80-300mm). Sizes 14-20" (350-500mm) utilize a tangential pin which is locked in place with a stainless steel set screw.



### **High Temperature Applications**

For operating temperatures to 290° F (143°C), EPDM seat material and packing, high temperature bearings and high temperature paint on the disc are available as standard options. Other seat materials for higher temperatures available on application.

# 3-20" (80-500mm) Design

## Integral Shaft Bearing Seals

To ensure all components of the valve remain maintenance-free, the molded-in body seat and body liner contain integral shaft bearing seals in the upper and lower journals. These seals protect bearing journal areas against sedimentation, mineral deposits, and corrosion particles — all of which can damage bearings and shorten valve life.

## Seat-In-Body vs. Seat-On-Disc

DeZURIK's AWWA Butterfly began its evolution over 40 years ago. For over 25 years, a stationary rubber seat located in the valve body has been the standard. This feature is fundamental to the long-term performance of the valve.

After years of service, water distribution valves and pipelines (regardless of material) suffer the effects of abrasive corrosion and tuberculation buildup. When the rubber seat of a butterfly valve is located on the moving disc edge, it will erode or tear away as it plows its way through line buildup, causing the valve to leak. With a rubber seat-in-body design, the stainless steel disc provides the resistance necessary to plow through line buildup without seat-on-disc edge damage.

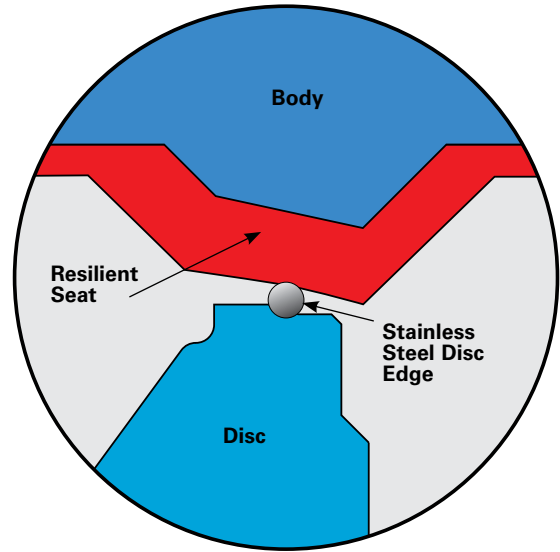

## Offset Disc Design

The offset disc provides an uninterrupted 360° sealing surface. The sealing surface is not interrupted by the valve shaft and does not have any continuous contact points between the rubber seat and the disc edge. This results in a longer seat life.

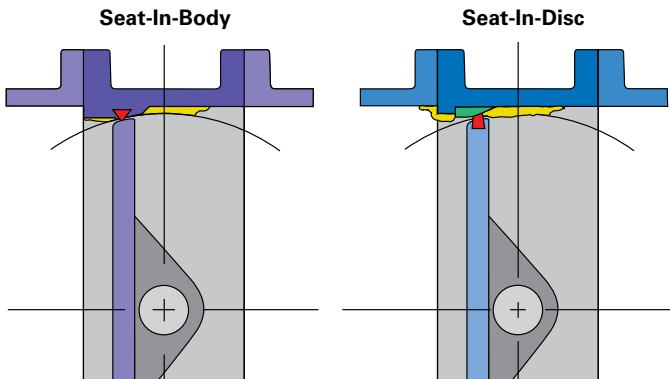

## Stainless Steel Disc Edge

Solid 316 stainless steel disc edge provides the corrosion and abrasion resistance essential for long-lasting, maintenance-free service. The stainless steel disc edge is on all disc materials including iron, carbon steel and aluminum bronze discs.



# 24" (600mm) and Larger Design

## Quality Features for Superior Performance

### Body Styles

Flanged, ASME B16.1 Class 125,  
24–120" (600–3000mm), Valve Class 150B

Flanged, ASME B16.1 Class 125,  
30–72" (750–1800mm), Valve Class 75B

Flanged, ASME B16.1 Class 125,  
30–48" (750–1200mm), Valve Class 25A

Flanged, ASME B16.1 Class 125,  
20–54" (600–1400mm), Valve Class 250B

Flanged, ASME B16.1 Class 250,  
24–48" (600–1200mm), Valve Class 250B

Mechanical Joint, ANSI/AWWA C111/A21.11,  
24–48" (600–1200mm), Valve Class 150B

Mechanical Joint, ANSI/AWWA C111/A21.11,  
24–48" (600–1200mm), Valve Class 250B

### Corrosion Resistant Shaft Material

Standard shaft materials include 304, 316, and 17-4 PH stainless steel, providing the corrosion resistance in the bearing and packing journal areas necessary to ensure long bearing and packing life.

### Stainless Steel Disc Edge

Solid 316 stainless steel disc edges provide a corrosion and abrasion resistant seating area essential for long-lasting, maintenance-free service.

### Choice of Seat Materials

Standard seat materials include Acrylonitrile Butadiene (NBR) for water service and EPDM for high temperature applications such as air blower lines.

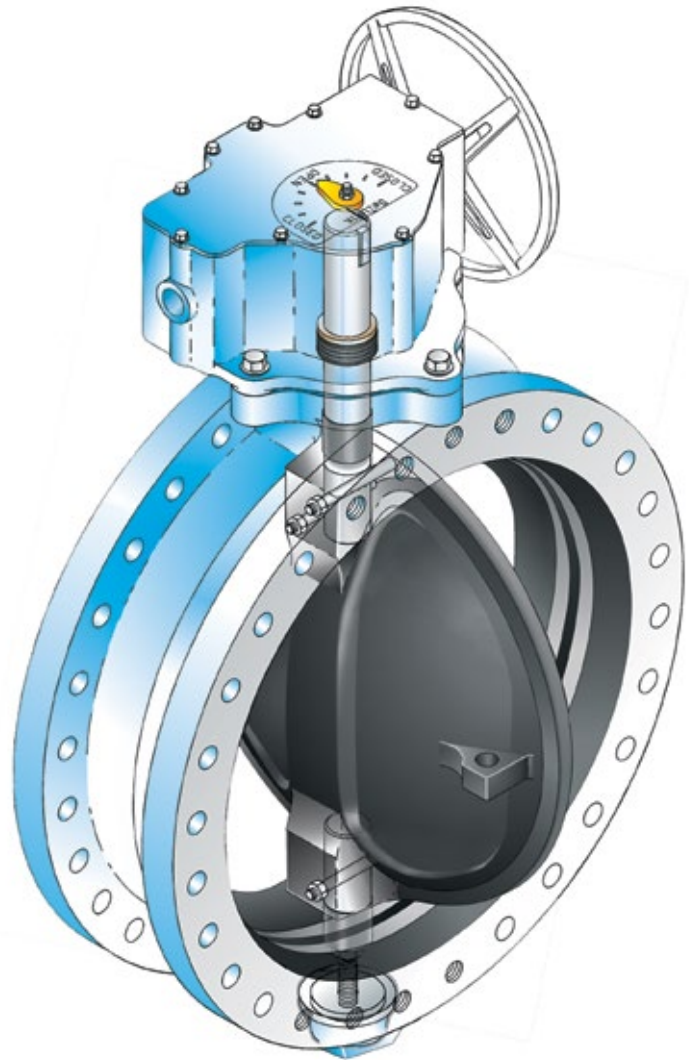

### High Temperature Applications

For operating temperatures to 290°F (143°C), EPDM seat material and packing, high temperature bearings and high temperature paint on the body and disc are standard. Other seat materials for higher temperatures available on application.

### Positive Disc Locators

Incorporated into the lower shaft is an adjustable thrust bearing assembly which holds the disc position in all possible installation orientations. This thrust bearing absorbs forces from the disc weight, internal hydraulics and axial shaft loads.



# 24" (600mm) and Larger Design

## Rugged Disc Structure

DeZURIK utilizes state-of-the-art design and analysis computer software and test equipment to develop the optimum disc structure. Larger valves have an open disc structure, allowing water to flow through the center ports of the disc. On smaller sizes, DeZURIK utilizes a dome disc structure. On all valve sizes the disc structure is non-hollow, allowing inspection of each surface and wall thickness against shrinkage and core shift during the casting process.

## Seat Design

DeZURIK's large valve seat design is industry proven and offers reliability, low operating torque and long life. The rubber seat is retained within a dovetail groove in the valve body and locked in place by an epoxy wedge. This design eliminates the need for fasteners, retaining rings or retaining segments to lock the seat in place. After the valve is fully assembled, with the disc in the closed position, an epoxy compound is injected behind the rubber seat and cured at a predetermined pressure based on the valve's pressure class. The injection pressure controls the interference between the rubber and stainless steel disc edge, providing a level of seating performance virtually impossible to achieve with other seat designs.

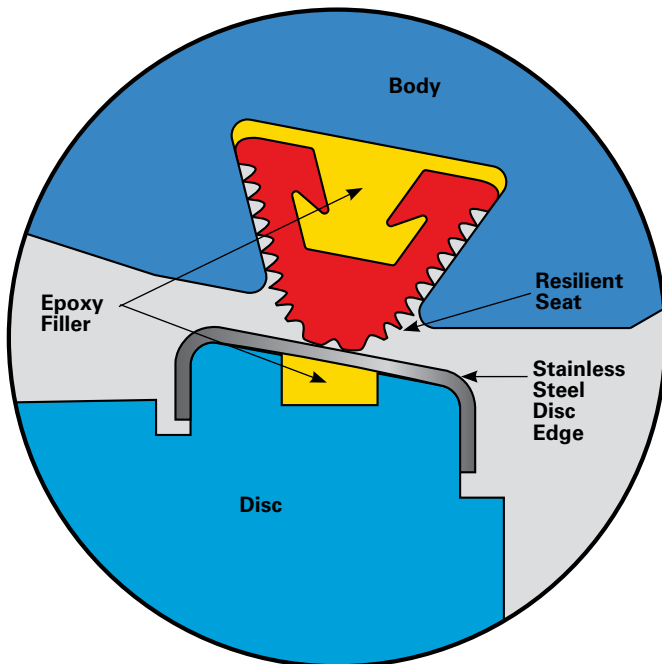

## Adjustable, Replaceable Seat

As required by AWWA C504 for valves 24" (600mm) and larger, this seat design offers field adjustment and replacement capabilities. Proper field adjustment can be performed from either the upstream or downstream side of a pressurized valve.

## Proven Disc-To-Shaft Pinning

Disc-to-shaft pinning is provided by a stainless steel tapered pin on sizes 24" (600mm) and larger. This proven design provides a reliable, high strength connection that conforms to AWWA C504.

## Long Life, Low Friction Bearings

The upper and lower journal shaft bearings are designed to provide high compressive strength, low friction and require no lubrication.

## Self-Compensating Shaft Seals

Shaft seals are self-compensating, V-type packing. DeZURIK uses a minimum of four sealing rings. This proven multi-ring sealing technology offers reliability and continuous self-adjustment. Standard packing materials include Acrylonitrile-Butadiene (NBR) or EPDM to meet all application requirements.

## Offset Disc Design

The offset disc provides an uninterrupted 360° sealing surface. The sealing surface is not interrupted by the valve shaft and does not have any continuous contact points between the rubber seat and the disc edge. This results in a longer seat life.



# Materials of Construction

3-16" (80-400mm)

18 & 20" (450 & 500mm)

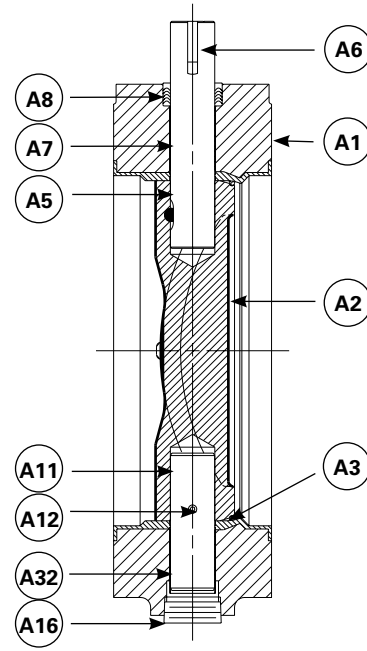
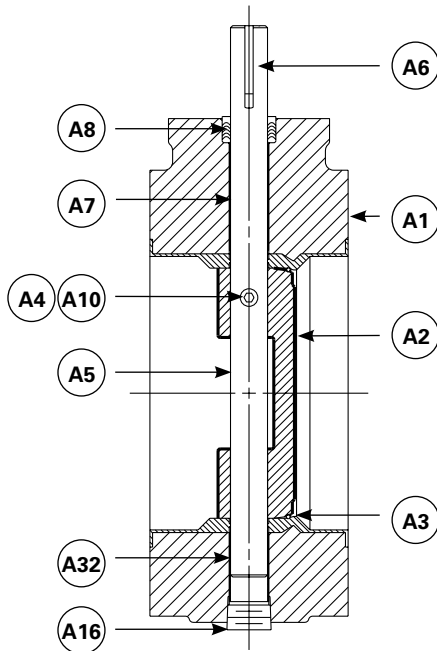

## 3-20" (80-500mm) Valve Sizes

Item	Description	Material
A1	Body NBR or EPDM seat is permanently bonded to the body	Cast Iron ASTM A126 Class B Ductile Iron ASTM A536 Grade 65-45-12
A2	Disc	Cast Iron ASTM A48 Class 40C Ductile Iron ASTM A536 Grade 65-45-12 316 Stainless Steel, ASTM A743, Type CF8M Aluminum Bronze, C95500, ASTM B763/B271/B505
A3	Disc Seating Edge	316 Stainless Steel, ASTM A276, Type 316 316 Stainless Steel, ASTM A743, Type CF8M
A4	Tangential Pin 14-20" (350-500mm)	316 Stainless Steel, ASTM A276, Type 316 (250B) 17-4 PH Stainless Steel, H1100
A5	Shaft 3-16" (80-400mm) Upper Shaft 18-20" (450-600mm)	304 Stainless Steel, ASTM A276, Type 304 316 Stainless Steel, ASTM A276, Type 316 17-4 PH Stainless Steel, ASTM A564, Type 630 Condition 1150
A6	Key	Steel AISI 1018
A7	Upper Journal Bearing	Nylon and Molybdenum Disulphide Composition (NBR Seat) PTFE (EPDM Seat) (250B) PTFE Fabric Liner, Fiberglass back-up shell
A8	Packing	Acrylonitrile Butadiene (NBR Seat) Ethylene Propylene Diene Terpolymer (EPDM Seat)
A10	Torque Screw 3-12" (80-300mm)	316 Stainless Steel, ASTM A276, Type 316 (250B) 17-4 PH Stainless Steel, Condition 1100
A10	Set Screw 14-20" (350-500mm)	18-8 Stainless Steel
A11	Lower Shaft 18-20" (450-600mm)	304 Stainless Steel, ASTM A276, Type 304 316 Stainless Steel, ASTM A276, Type 316 17-4 PH Stainless Steel, ASTM A564, Type 630 Condition 1150
A12	Set Screw 18-20" (450-500mm)	18-8 Stainless Steel
A16	Plug 3-20" (80-500mm)	3-8" (80-200mm) Carbon Steel, SAE J403, Grade 1008/1010 10-20" (250-500mm) Malleable Iron, ASTM A47-52 Grade 35018 (250B, 3-6" (80-150mm)) Carbon Steel, SAE J403, Grade 1008/1010 (250B, 8-20" (200-500mm)) Malleable Iron, ASTM A47-52 Grade 35018
A32	Lower Journal Bearing	Nylon and Molybdenum Disulphide Composition (NBR Seat) PTFE (EPDM Seat) (250B) PTFE Fabric Liner, Fiberglass back-up shell

# Materials of Construction

## 24-72" (600-1800mm) Valve Sizes

Item	Description	Material
A1	Body	Cast Iron, ASTM A126 Class B Ductile Iron, ASTM A536 Grade 65-45-12
A2	Seat	Acrylonitrile-Butadiene (NBR) Terpolymer of Ethylene, Propylene and a Diene (EPDM)
A6	Thrust Bearing Cover	Cast Iron, ASTM A126 Class B Ductile Iron, A536 Grade 65-45-12
A7	Screw	18-8 Stainless Steel
A8	O-Ring	Acrylonitrile-Butadiene (NBR) Terpolymer of Ethylene Propylene and a Diene (EPDM)
A9	Thrust Collar	Steel, ASTM 108
A10	Set Screw	18-8 Stainless Steel
A11	Disc	Cast Iron ASTM A48 Class 40C Ductile Iron ATM A536 Grade 65-45-12
A12	Disc Edge	316 Stainless Steel, ASTM A240, Type 316
A13	Disc Pin	24-48" (600-1200mm) 304 Stainless Steel, ASTM A276, Type 304 54-72" (1400-1800mm) 303 Stainless Steel, ASTM 582, Type 303
A14	Nut	18-8 Stainless Steel
A15	Upper Shaft	304 Stainless Steel, ASTM A276, Type 304 316 Stainless Steel, ASTM A276, Type 316 17-4 PH Stainless Steel, ASTM, Type 630 Condition 1150
A16	Key	Steel AISI 1018
A17	Bearing	PTFE Fabric Liner, Fiberglass back-up shell
A19	Packing	NBR Acrylonitrile-Butadiene (NBR Seat) EPDM Ethylene Propylene and a Diene (EPDM Seat)
A20	Spacer 30-48" (750-1200mm)	316 Stainless Steel, ASTM A276, Type 316
A22	Gland 60-72" (1500-1800mm)	Bronze ASTM B-62
A23	Screw (Used with A22)	18-8 Stainless Steel
A24	Washer (Used with A22)	18-8 Stainless Steel
A25	Lower Shaft	304 Stainless Steel, ASTM A276, Type 304 316 Stainless Steel, ASTM A276, Type 316 17-4 PH Stainless Steel, ASTM, Type 630 Condition 1150
A26	Adjusting Screw	303 Stainless Steel, ASTM A582, Type 303
A27	Jam Nut	18-8 Stainless Steel
A29	Thrust Plate	Carbon Steel AISI A108
A30	Screw 24-48" (600-1200mm)	18-8 Stainless Steel
A31	Lockwasher 24-48" (600-1200mm)	18-8 Stainless Steel
A32	Epoxy	Epoxy
A33	O-Ring	Acrylonitrile-Butadiene (NBR) Terpolymer of Ethylene Propylene and a Diene (EPDM)

Contact DeZURIK for materials of construction on valve sizes 78-120" (2000-3000mm).

## 24-42" (600-1100mm)

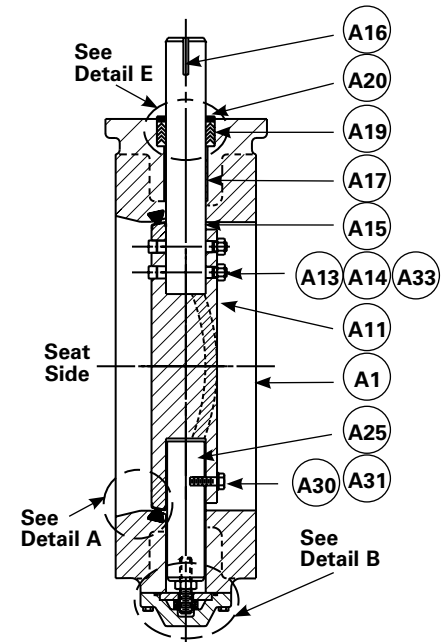

## 48-72" (1200-1800mm)

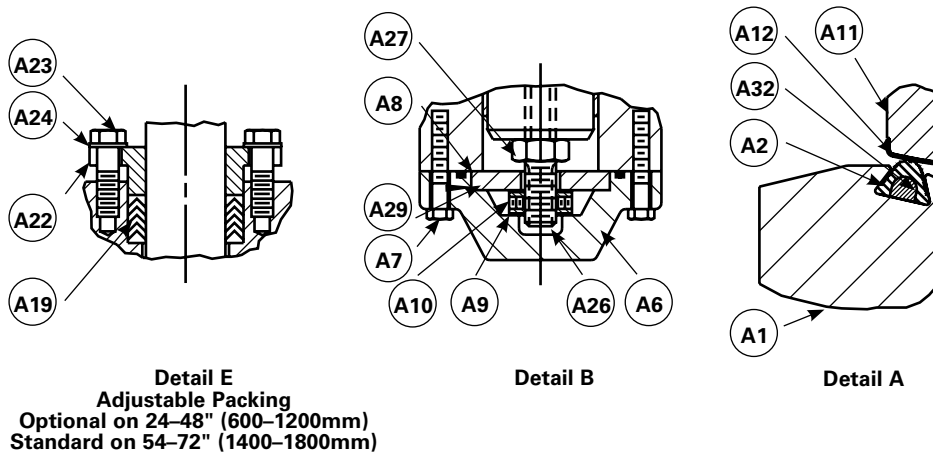
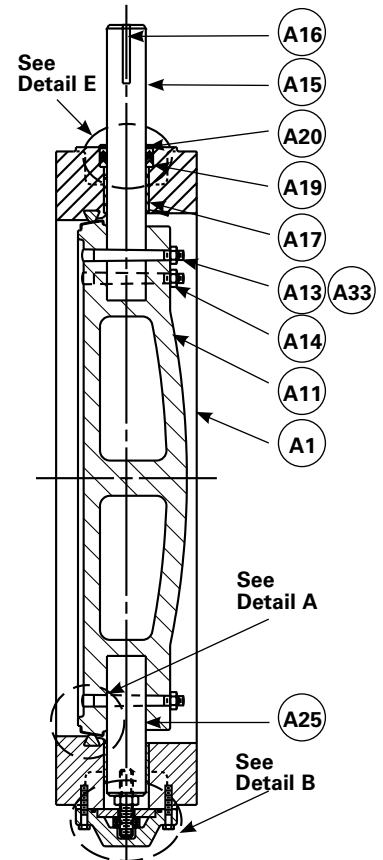



# Valve Selection

## Cv/Kv Values\*

### Class 150B

Valve Size	100% Cv/Kv	
	Flat Cv/Kv	Dome Cv/Kv
3" 80mm	362 313	356 308
4" 100mm	658 569	646 559
6" 150mm	1,380 1,194	1,360 1,176
8" 200mm	2,440 2,111	2,390 2,067
10" 250mm	3,910 3,382	3,840 3,322
12" 300mm	5,730 4,960	5,630 4,870
14" 350mm	7,840 6,782	7,700 6,661
16" 400mm	10,200 8,823	9,980 8,633
18" 450mm	12,600 10,899	12,400 10,726
20" 500mm	15,800 13,667	15,500 13,408
24" 600mm	22,900 19,809	22,500 19,463

### Class 25A, 75B, 150B

Valve Size	100% Cv/Kv	
	Flat Cv/Kv	Dome Cv/Kv
30" 750mm	36,500 31,573	35,900 31,054
36" 900mm	53,200 40,018	52,300 45,240
42" 1100mm	73,100 63,232	71,800 62,107
48" 1200mm	109,000 94,285	103,000 89,095
54" 1400mm	140,000 121,100	131,000 113,315
60" 1500mm	173,000 149,645	163,000 140,995
66" 1700mm	210,000 181,650	198,000 171,270
72" 1800mm	250,000 216,250	236,000 204,140

Contact DeZURIK for Cv/Kv Values on 78-120" (2000-3000mm) valves and for Class 250B.

\* Cv = Flow in GPM of water at 1 psi pressure drop.  
Kv = Flow in m<sup>3</sup>/hr. of water at 100 kPa pressure drop.

**Flow characteristic 3-42" (80-1100mm)**

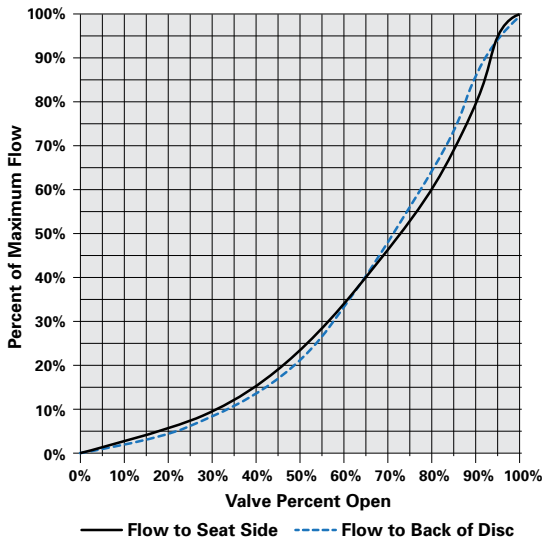

**Flow Characteristic 48-72" (1200-1800mm)**

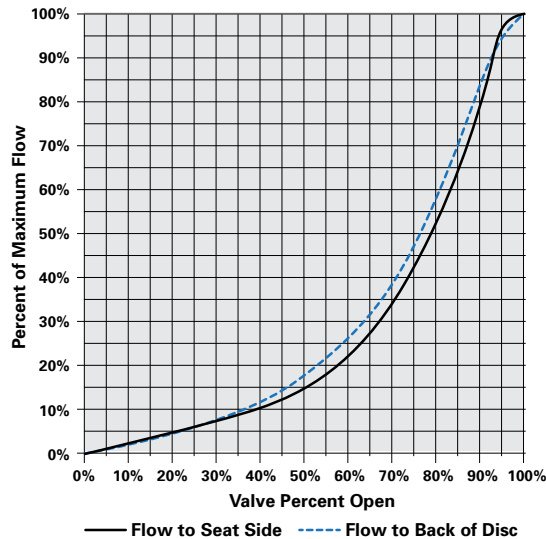

## Applicable Standards

DeZURIK BAW AWWA Butterfly Valves are designed and/or tested to meet the following standards:	
ANSI/AWWA C111/A21.11	Mechanical Joint Bell dimensions conform to ANSI/AWWA C111/A21.11, Rubber Gasket Joints for Ductile Iron and Gray Iron Pressure Pipe Fittings.
ANSI/AWWA C-504	Valves conform to AWWA Standard ANSI/AWWA C-504 for sizes 3-72" (80-1800mm) Rubber Seated Butterfly Valves. Standard interior and exterior coatings meet the requirements of this standard.
ANSI/AWWA C-516	Valves conform to AWWA Standard ANSI/AWWA C-516 for sizes 78" (2000mm) & larger Rubber Seated Butterfly Valves. Standard interior and exterior coatings meet the requirements of this standard.
ASME B16.1	Dimensions and drilling of flanged end connections on valves up to 96" (2400mm) conform to Class 125 sections of ASME B16.1 Cast Iron Pipe Flanges and Flange Fittings.
ASTM D429	Bonding of 3-20" (80-600mm) seats conforms to ASTM D429, Standard Test Methods for Rubber Property - Adhesion to Rigid Substrates.
ASTM D471	Seat material volume increase is less than 2% after immersion in distilled water for 70 hours, when tested in accordance with ASTM D471, Standard Test Method for Rubber Property - Effect of Liquids.
ASTM D1149	Ozone resistance of seat material conforms to ASTM D1149, Standard Test Method for Rubber Deterioration - Surface Ozone Cracking in a Chamber.
AWWA C110	Ductile-Iron and Gray-Iron Fittings, Mechanical Joint Accessories 30-48" (750-1200mm) meet this standard.
AWWA C153	Ductile-Iron Compact Fittings, Mechanical Joint Accessories 4-24" (100-600mm) meet this standard.
AWWA C207	For sizes 102" (2600mm) and larger, flange bolt patterns comply with AWWA C207 and flange thickness complies with AWWA C516.

## Basic Valve Weights\*

Valve Size	Flanged F1	Flanged F2	Mechanical Joint
	All Classes	Class 250B	Class 150B (Use for Class 250B)
3" 80mm	33 15	45 21	—
4" 100mm	45 21	62 29	50 23
6" 150mm	65 30	90 41	76 35
8" 200mm	100 46	144 66	112 51
10" 250mm	156 71	207 94	123 56
12" 300mm	250 114	312 142	213 97
14" 350mm	325 148	454 206	238 108
16" 400mm	383 174	538 245	398 181
18" 450mm	428 195	596 271	444 202
20" 500mm	547 249	773 351	570 259
24" 600mm	1025 466	1435 652	1025 466
28" 700mm	1360 618	—	—
30" 750mm	1850 840	2405 1092	1850 840
36" 900mm	2800 1271	3640 1652	2800 1271
42" 1050mm	4050 1838	5265 2389	4050 1838
48" 1200mm	5750 2609	7475 3392	5750 2609
54" 1400mm	7500 3403	—	—
60" 1500mm	9825 4458	—	—
66" 1700mm	12100 5491	—	—
72" 1800mm	15150 6874	—	—
Contact DeZURIK for weights on valve sizes 78" (2000mm) and larger.			

lbs

kilograms

\* Weights are approximate and do not include crating or actuators.

# Ordering

## Valve Style

### Give valve style code as follows:

BAW = AWWA Butterfly Valve

## Valve Size

### Give valve size code as follows:

3" (80mm)	42" (1100mm)
4" (100mm)	48" (1200mm)
6" (150mm)	54" (1400mm)
8" (200mm)	60" (1500mm)
10" (250mm)	66" (1700mm)
12" (300mm)	72" (1800mm)
14" (350mm)	78" (2000mm)
16" (400mm)	84" (2100mm)
18" (450mm)	90" (2300mm)
20" (500mm)	96" (2400mm)
24" (600mm)	102" (2600mm)
28" (700mm)	108" (2700mm)
30" (750mm)	114" (2900mm)
36" (900mm)	120" (3000mm)
	144" (3600mm)

**Note:** All orders for 28" (700mm) and larger must include valve pipeline mounting position and shaft orientation as second line information.

## End Connection

### Give end connection code as follows:

F1 = ASME 125 Flanged 3-96" (80-2400mm)  
 AWWA C207 Class B & C Flanged 102-144" (2600-3600mm)  
 F2 = ASME 250 Flanged 3-48" (80-1200mm)  
 MJ = Mechanical Joint 4-48" (100-1200mm)  
 With Mechanical Joint ends, buriable actuators are recommended.

## Body Material

### Give body material code as follows:

CI = Cast Iron - F1 or MJ  
 CS = Carbon Steel - F1, 24" & larger (600mm & larger)  
 DI = Ductile Iron - F1, F2, or MJ  
 S2 = 316 Stainless Steel - F1, 24" & larger (600mm & larger)

## Packing/Seat Combination

### Give packing/seat material codes as follows:

#### Packing Material

NBRN = Acrylonitrile-Butadiene Self-Adjusting 3-144" (80-3600mm)  
 -20 to 180°F (-29 to 82°C)  
 NBRA = Acrylonitrile-Butadiene Adjustable 3-144" (80-3600mm)  
 -20 to 180°F (-29 to 82°C)  
 Do not use with buried service  
 EPDN = EPDM Self-Adjusting -20 to 290°F (-29 to 143°C)  
 3-48" (80-1200mm)  
 EPDA = EPDM Adjustable -20 to 290°F (-29 to 143°C)  
 3-48" (80-1200mm)  
 Do not use with buried service.  
 TCN = PTFE Self-Adjusting -20 to 450°F (-29 to 232°C)  
 3-144" (80-3600mm)  
 TCA = PTFE Adjustable -20 to 450°F (-29 to 232°C)  
 28-144" (700-3600mm)  
 Do not use with buried service.

#### Seat Material

NBR = Acrylonitrile-Butadiene -20 to 180°F (-29 to 82°C)  
 Must use NBRN or NBRA packing.  
 EPDM = Terpolymer of Ethylene Propylene & a Diene  
 -20 to 290°F (-29 to 143°C)  
 Must use EPDA or EPDN, TCN or TCA packing.

## Class AWWA C-504

### Give AWWA Class code as follows:

25A = 28-48" (700-1200mm) Flanged  
 75B = 28-144" (700-3600mm) Flanged  
 150B = 3-144" (80-3600mm) Flanged  
 4-48" (100-1200mm) Mechanical Joint  
 250B = 3-144" (80-3600mm) Flanged  
 4-48" (100-1200mm) Mechanical Joint

**Note:** Pressure ratings above 150 not available with EPDM Seat on valves 24" & larger (600mm & larger).

## Disc/Shaft Combination

### Give disc/shaft code as follows:

#### Disc Material

CI = Cast Iron disc with 316 stainless steel edge (3-20" only)  
 DI = Ductile Iron disc with 316 stainless steel edge  
 S2 = 316 Stainless Steel  
 ALB = Aluminum Bronze (3-18" only)  
 CS = Carbon Steel, 24" & larger (600mm & larger)

## Shaft & Pin Material

### Give shaft & pin material code as follows:

S1 = 304 Stainless Steel shaft  
 Pin is 316 Stainless Steel on 3-36" (80-900mm)  
 and 304 Stainless Steel on 42-144" (1100-3600mm)  
 S5 = 17-4 pH Stainless Steel shaft & pin (must be used with 250B)  
 S2 = 316 Stainless Steel shaft & pin

## Options

### Give options code as follows:

AIS = Valves conform to H.R. 3547 Consolidated Appropriations Act,  
 2014 Section 436  
 DTR = DeZURIK Standard Certified Production Hydrostatic Shell and  
 Seat Test Report  
 BAA = Buy American Act  
 CMC = Certificate of Material Conformance  
 TB = DeZURIK Standard Certified Hydrostatic Shell Test and Seat  
 Leak Test, both directions

## Ordering Example:

BAW,24,F1,CI,NBRN-NBR,150B,DI-S1\*Actuator

## Mechanical Joint Accessories

Accessories include bolts, nuts, packing and glands for both ends. Sizes 4-24" (100-600mm) meet AWWA C153. Sizes 30-48" (750-1200mm) meet AWWA C110. Order as a separate item by giving code ACC\*MJ-valve size.



# Manual Actuators

## Lever Actuators



A 10-position dial provides positive latching in open, closed and eight intermediate positions. A pointer indicates position of disc plus a notch in the handle allows use of a padlock to prevent unauthorized valve operation.

### Mounting

Lever actuators can be mounted at standard or 180°. Levers are available on 3–8" (80–200mm) valve sizes.



## Rotary Manual Actuators

DeZURIK offers a variety of rotary manual actuator options which are in complete compliance with AWWA C504. Manual actuators are available with handwheel, chainwheel or 2" (80mm) square nut options.

### Easily Adjustable Stops

Open and closed position stops can be easily adjusted without drilling, shimming or pinning. The stops ride the input shaft and can be repositioned with a simple adjustment of the stop nut.

### Rugged Designs

Manual actuators are sized to operate with a maximum input of 150 foot pounds on 2" (80mm) square operating nuts, and can be sized for 40 or 80 pound rim pull on handwheels and chainwheels. The actuators are self-locking, maintaining valve position under varying flow conditions.

### Buriable and Weatherproof Construction

DeZURIK actuators feature a cast iron housing in buriable or weatherproof construction. The mechanism is totally enclosed and does not require lubrication for routine maintenance. Buried service actuators are grease filled per AWWA C504.

### Valve Position Indicator

The pointer on weatherproof actuators clearly indicates the valve position marked on top of the housing. The indicator shaft is sealed to keep moisture from entering the actuator housing.

### Easily Rotatable

The four keyways in the yoke make DeZURIK nut and handwheel manual actuators easy to rotate to any of four mounting positions. Chainwheel actuators can be mounted at standard and 180°.

### Mounting

Nut & Handwheel

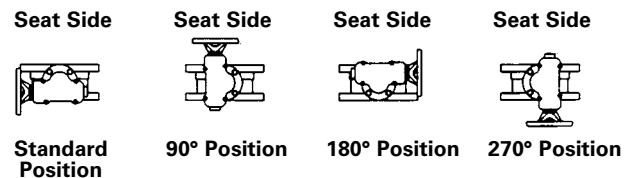

Chainwheel

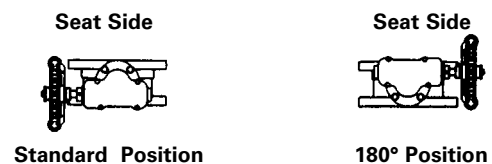

# Manual Actuators

## G-Series Design

The G-Series design is available on 3–30" (80–750mm) valve sizes with a handwheel, chainwheel or 2" square nut input. The worm gear mechanism allows the G-Series actuators to provide high output torque with a torque curve matching the torque required by the valve. G-Series actuators feature a steel worm and ductile iron gear.

### 300 & 450 Foot Pound Input Torque

As required by AWWA C504, an input torque of 300 foot pounds against the fully adjustable open and closed position stops is standard. A 450 foot pound input capability against the stops is an option.

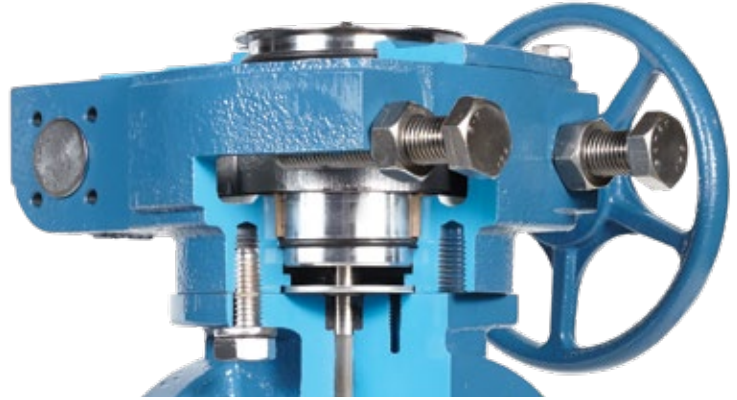

## LA-Series Design

The LA-Series design is available on 30–72" (750–1800mm) valve sizes. The link-arm mechanism allows the LA-Series actuator to provide characterized closure which slows valve travel as the disc comes into the seat. The actuators feature high compressive strength yoke nut bearings which ensure reliable operation and increase cycle life.

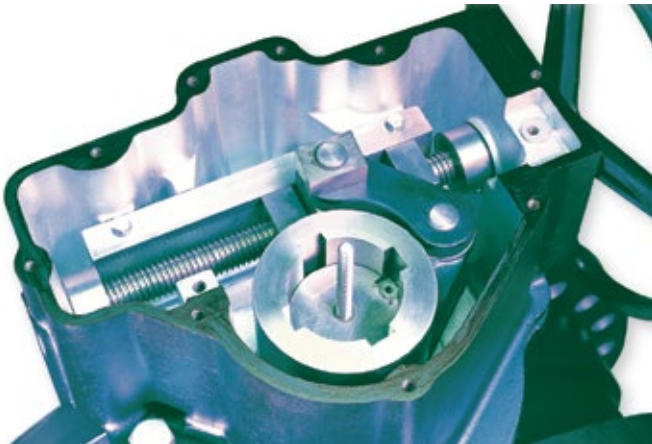

### High Output Torque

The LA-Series actuators feature an input torque capability of 450 foot pounds against the open and closed position stops as standard. An optional spur gear provides a 2:1 mechanical advantage while maintaining an input torque capability of 300 foot pounds against the stops. The spur gear slows closing of the valve, minimizing the possibility of water hammer.

### 450 Ft-Lb Input Stops

LA-Series actuators have 450 Ft-Lb input stops as standard.

# Rotary Manual Actuators

## GS/GB-6B Materials of Construction

Item	Description	Material
B1A	Housing	Cast Iron, ASTM A126, Class B
B1B	Cover	Cast Iron, ASTM A126, Class B
B1C	Gear	Ductile Iron, ASTM A536, Grade 80-55-06
B1D	Worm	Steel, EN19 or ASTM A322, Grade 1440, UNS G14400
B1L	Bearing	Bronze, Oil Impregnated
B1F	Drive Shaft	Stainless Steel, Type 431 ASTM 276
B1G	Bearing Race	Steel
B1H	Thrust Bearing	Steel
B1I	Pipe Plug	18-8 Stainless Steel, ANSI B16.14
B1J	Shaft Seal	Acrylonitrile-Butadiene (NBR) and carbon steel case
B1K	Pin	Type H Steel EN8 Rockwell C20-25, ANSI B18.8.2
B1E	Bearing	Bronze, Oil Impregnated, ASTM B438, Grade 1, Type 2
B1M	Screws	A2-70, DIN933 (comparable to Stainless Steel 18-8)
B1N	O-ring	Acrylonitrile-Butadiene (NBR)
B1O	Nut	A2, DIN439B, (comparable to Stainless Steel 18-8)
B1P	Screw	A2-80, DIN933 (comparable to Stainless Steel 18-8)
B1Q	Pointer	Steel Zinc Plated, ASTM 569
B1R	Screw	A2 (comparable to Stainless Steel 18-8) ANSI B18.3.4M
B1S	Plug, Tapered	Plastic 238-D
B1T	Plug	Steel, ASTM A108, UNS G1018
B1U	Packing Washer	316 Stainless Steel, ASTM A276, UNS S31600
B1V	Spacer Sleeve	Steel EN 19 or ASTM A322, Grade 4140 UNS G41400

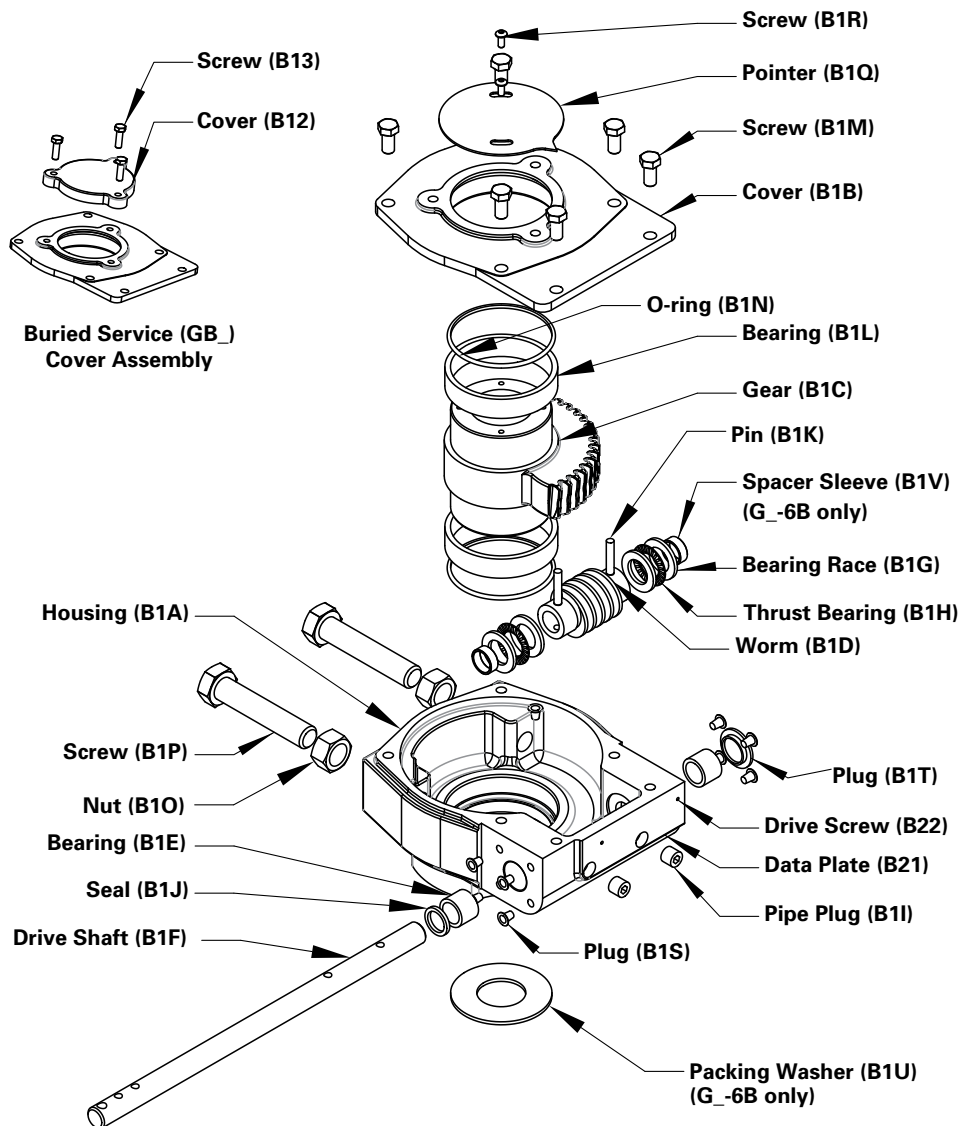



# Rotary Manual Actuators

## LA-Series Actuator Materials of Construction

Item	Description	Material
B1	Housing	Cast Iron, ASTM A126 Class B
B2	Bearing	Bronze Oil Impregnated
B3	Yoke	Ductile Iron, ASTM A536 80-55-06
B4	Cover	Steel Plate, A36 HR
B5	Packing Retainer	Steel Plate, A36 HR
B6	Link	Steel
B7	Yoke Nut	Ductile Iron, ASTM A536 80-55-06
B8	Guide Nut (LA-4 & LA-6)	Powder Metal 8020 23B
B9	Retaining Ring	Carbon Steel, SAE 1060-1090
B10	Input Shaft	Steel, AISI 1141
B11	O-Ring	Acrylonitrile-Butadiene
B12	O-Ring	Acrylonitrile-Butadiene
B13	Collar	Steel, AISI 1215
B14	Pin	Steel
B15	Thrust Washer	Teflon/Glass Fabric, Stainless Steel Backing
B16	Thrust Washer	Teflon/Glass Fabric, Stainless Steel Backing
B17	Bearing	Bronze Oil Impregnated
B18	Expansion Plug	Steel Zinc Plated
B23	Retaining Washer	Stainless Steel, Type 18-8
B24	Outer Guide Bar	Steel, AISI 1018
B25	Inner Guide Bar	Steel, AISI 1018
B26	Square Nut	Steel, AISI 1018
B27	Stop Nut	Steel, AISI 1018
B28	Seal	Steel with Nitrile
B29	Pointer	Steel, ASTM A36
B32	Stud	Steel Zinc Plated
B33	Nut	Steel Zinc Plated
B34	Thread Seal	Steel with Nitrile
B35	Yoke Cover	Steel, ASTM A569
B40	Pin	Steel Zinc Plated
B43	Handwheel	Cast Iron, ASTM A126 Class B
B44	Position Plate	Vinyl
B45	Shim	Steel
B47	Expansion Plug	Steel Zinc Plated

Item	Description	Material
B48	Bushing	Bronze Oil Impregnated
B50	Chain Guide	Cast Iron, ASTM A126
B51	Closing Link	Steel
B52	Collar	Steel, ASTM A36
B53	Bearing	Bronze
B54	Screw	Steel Zinc Plated
B55	Washer	Steel Zinc Plated
B56	Retaining Ring	Carbon Steel
B57	Adaptor Plate	Steel, ASTM A36
B58	Seal	Garlock
B62	Bearing	Bronze
B63	Gasket	Non-Asbestos
B64	Adaptor	Cast Iron, ASTM A126 Class B
B65	Gasket	Non-Asbestos
B69	Housing (Spur Gear)	Cast Iron, ASTM A126
B70	Pin (Chainwheel)	Steel Zinc Plated
B71	Gasket	Fiber Non-Asbestos
B72	Screw	Steel Zinc Plated
B73	Screw	Steel Zinc Plated
B74	Seal	Steel Zinc Plated
B75	Pin	Steel Zinc Plated
B76	Pin	Steel Zinc Plated
B77	Retainer Ring	Steel Zinc Plated
B78	Cover	Steel Plate, ASTM A36
B81	Gear	Carbon Steel
B82	Gear	Carbon Steel
B83	Input Shaft (Spur Gear)	Steel, ASTM A29
B84	O-Ring	Nitrile
B85	Chainwheel	Cast Iron, ASTM A126 Class B
B88	Adaptor (Adj. Packing)	Steel, ASTM A36
B89	Bearing	Bronze
B90	Shaft Extension	Steel, AISI 1215
B91	Washer	Steel Zinc Plated
B92	Expansion Plug	Zinc Plated Steel
B93	Lockwasher	Zinc Plated Steel

Note: All fasteners are zinc plated steel unless stainless steel bolting is specified.

### LA-Series Handwheel

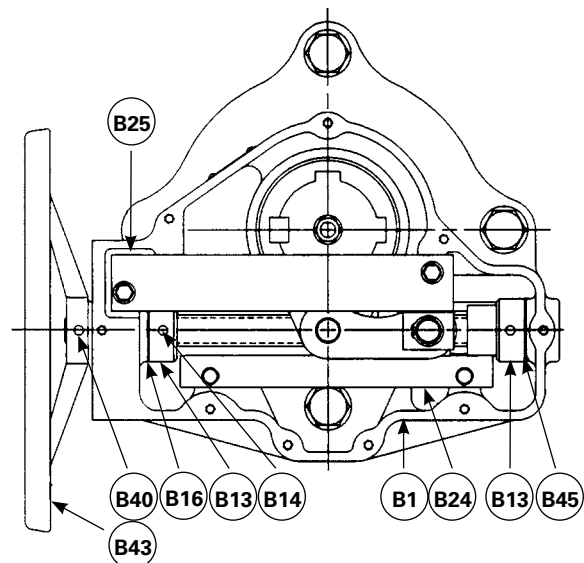
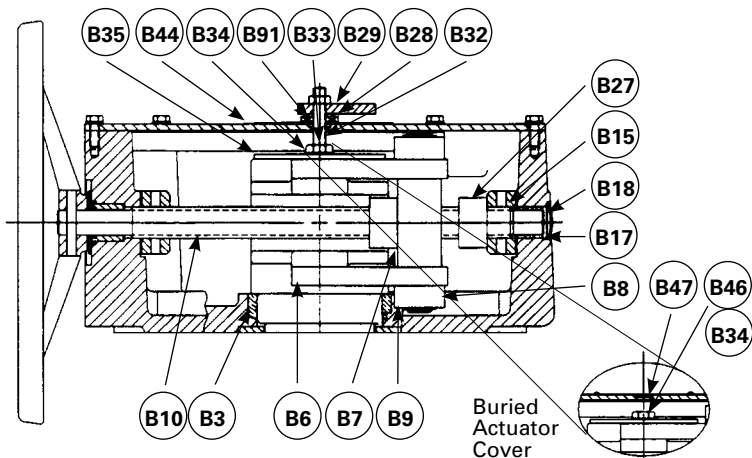



# Manual Actuator Accessories

## Tee Wrench

For use in actuating 2" (50mm) nut actuators. Available in 4, 5, 6, 7 or 8 foot lengths. Other lengths available on special order.

## Chain — For Chainwheel Actuators

Chain for chainwheel actuators are available in zinc plated, galvanized or 304 stainless steel.

## Stainless Steel Bolting

Includes stainless steel fasteners on valve and actuator.

## Clockwise Rotation

Clockwise rotation to open (open right). Available with GS/GB-6B-Series and LA Series Manual Actuators.

## Galvanized Chainwheel and Guide

Same as chainwheel actuator except chainwheel and guide are galvanized.

## Dial Indicating Floorstand

For valves with handwheel actuators. Actuator is mounted on the valve and the input shaft is extended to the floorstand. Included with the floorstand are the handwheel mounted on the floorstand, dial indicator and couplings. Extension rod must be ordered separately. Floorstand may be directly above valve or offset from valve location. A buried actuator must be specified when ordering an FSDI.

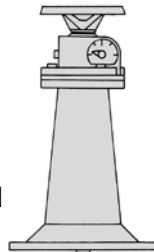

## Extension Rod

Extension rod is required for use with FSDI floorstand.

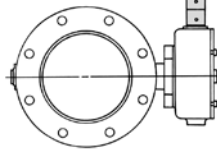

## Actuator Mounted on Floorstand

Included with floorstand are the couplings, extension pipe and mounting of actuator on floorstand.

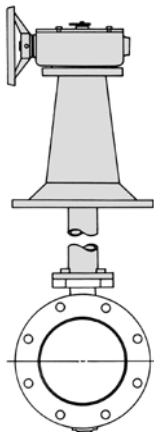

## Neck Extensions

Included is an extended valve neck and shaft. Valves for use with neck extensions must be furnished with non-adjustable packing and a non-buried actuator. Extensions are not recommended for use with positioners.

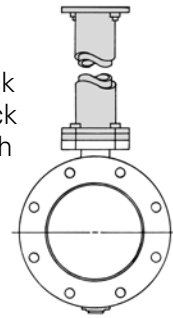

## Extended Nut for Manual Actuators

For actuators used with floorboxes and valve boxes. Includes couplings, extension rod and extended 2" (50mm) square nut.

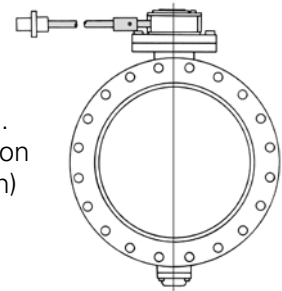

## Valve Box and Valve Box Extensions

For use with buried actuators. Includes valve box and cover. One to five extension pieces may be ordered to extend depth of valve box. Valve boxes may be used with valves having standard or extended nut actuators. Top of nut must be 6" (150mm) below grade. Valve boxes are tee wrench actuated. Tee wrenches must be ordered separately.

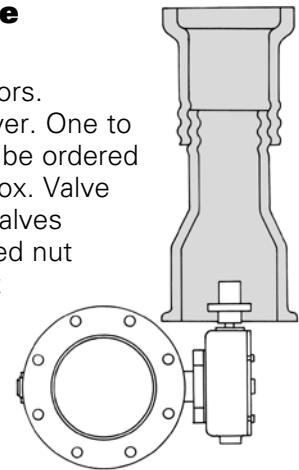

# Cylinder Actuators

DeZURIK cylinder actuators are available as double-acting pneumatic or water hydraulic cylinders for either on-off or positioning services.

All cylinder actuators are double-acting, stationary mounted with all working parts totally protected within weatherproof enclosures.

## C540 Cylinder Actuators

DeZURIK C540 pneumatic and hydraulic cylinder construction is in strict accordance with AWWA C540. The cylinder head and end cap are ductile iron. On pneumatic cylinders, interior surfaces are epoxy coated; on hydraulic cylinders, interior surfaces are nickel plated.

On pneumatic cylinders, the piston is epoxy coated cast iron and the piston rod is chrome plated carbon steel.

On hydraulic cylinders, the piston is nickel plated cast iron and the piston rod is chrome plated stainless steel.

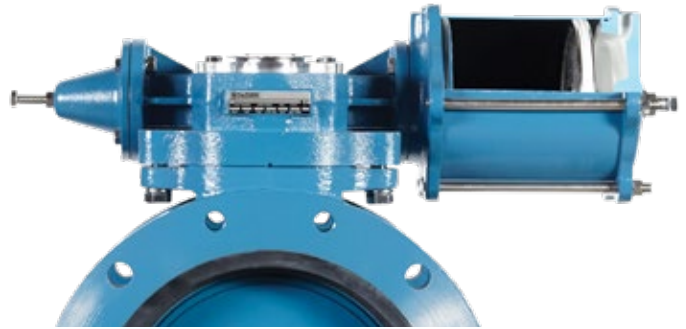

## Manual and Throttling Manual Override

Contact Application Engineering for assistance.

## Mounting

Cylinder actuators can be mounted at 90° increments from standard.

### T- Series

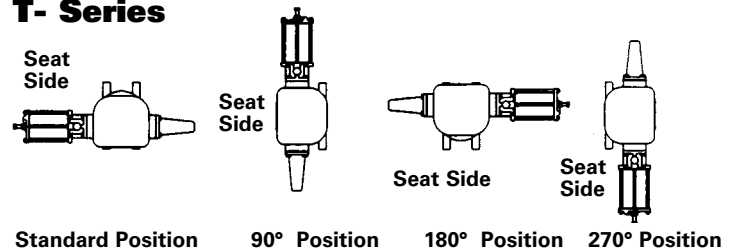

### G- Series

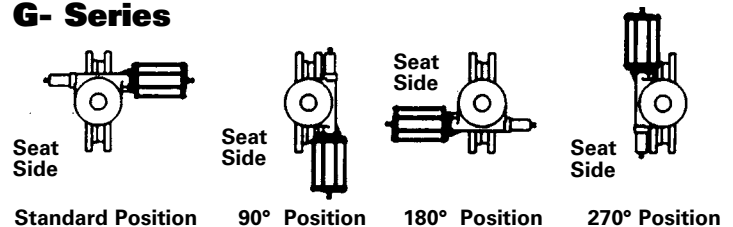

# Electric Motors

Electric motors offer reliable and economical valve operation. The electric actuator and associated gearing meet AWWA C540. DeZURIK AWWA Butterfly Valves can be furnished with electric motor actuators produced by leading manufacturers.

When ordering electric motor actuators, please provide information listed on "Data Input Checklist" at end of bulletin.

# Cylinder Actuators

## T-Series Cylinder Actuator Materials of Construction

Item	Description	Material
B1	Housing	Cast Iron, ASTM A126 Class B
B3	Bearing	Bronze
B5	Yoke	Cast Ductile Iron, A536
B6	Yoke Nut	Cold Rolled Steel
B7	Bearing	Sintered Stainless Steel
B11	Stop Nut	Cold Rolled Steel
B13	Guide Rail	Cold Rolled Steel
B19	Gasket	Neoprene
B23	Lower Yoke Guide (TW-7 only)	Steel, AISI 1215
B24	Upper Yoke Guide (TW-7 only)	Steel, ASTM A366
B25	Guide Rail (TW-7 only)	Steel, ASTM A36
B29	Gasket	Neoprene
B30	Cap	Fiberglass
B35	Stay Pin	Steel
B49	Screw	Alloy Steel
B50	Key	Steel, AISI 1018
B55	Adaptor (Hydraulic only)	Cast Iron, ASTM A126 Class B
B56	Wiper (Hydraulic only)	Carbon Steel

**Note:** All fasteners are zinc plated steel unless stainless steel bolting is specified.

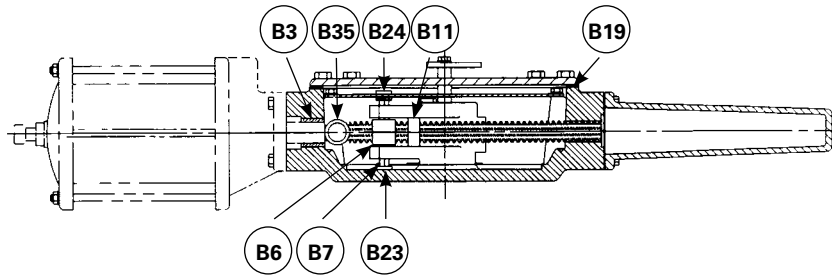

Construction as used with Water Hydraulic Cylinder

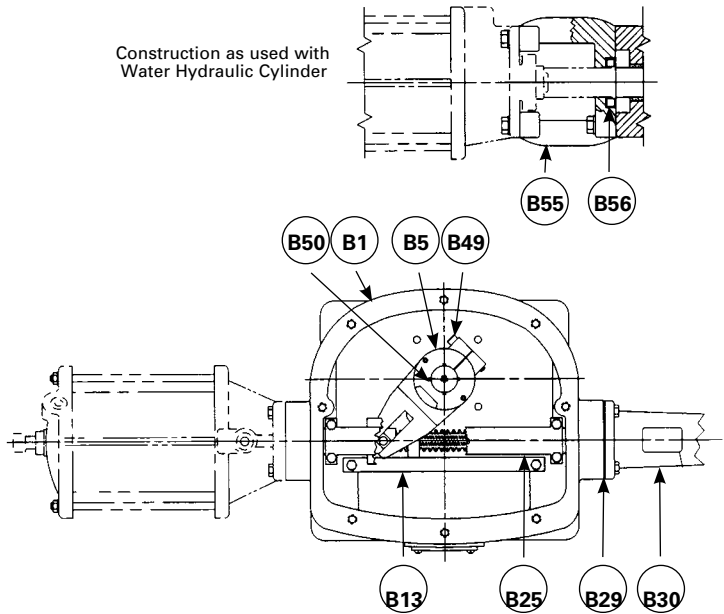

## Pneumatic/Low Pressure Oil Hydraulic Cylinder Materials of Construction

Item	Description	Standard Construction	C-540 Construction
C1	Cylinder Head	Cast Iron, ASTM A126 Class B	Ductile Iron, ASTM A536 65-45-12
C2	Bearing	Bronze Oil Impregnated	Bronze Oil Impregnated
C3	Rod Seal	Teflon with NBR	Teflon with NBR
C4	Piston Rod	Steel, AISI 1215 Chrome Plated	Steel, AISI 1215 Chrome Plated
C6	O-Ring	Acrylonitrile-Butadiene	Acrylonitrile-Butadiene
C7	Cylinder Tube	Fiberglass	Fiberglass
C8	Piston	Cast Iron, ASTM A126 Class B	Cast Iron, ASTM A126 Class B
C9	O-Ring	Acrylonitrile-Butadiene	Acrylonitrile-Butadiene
C10	Piston Seal	Virgin Teflon	Virgin Teflon
C11	Nut	Zinc Plated Steel	Zinc Plated Steel
C12	Cylinder Cap	Ductile Iron, ASTM A536 65-45-12	Ductile Iron, ASTM A536 65-45-12
C13	Tie Rod	Zinc Plated Steel	Steel, AISI C1018 Zinc Plated
C14	Washer	Zinc Plated Steel	Zinc Plated Steel
C15	Nut	Zinc Plated Steel	Zinc Plated Steel
C16	Seal Thread	Steel with Nitrile	Steel with Nitrile
C17	Jam Nut	Zinc Plated Steel	Zinc Plated Steel
C18	Set Screw	Zinc Plated Steel	Zinc Plated Steel
C19	O-Ring	Acrylonitrile-Butadiene	Acrylonitrile-Butadiene

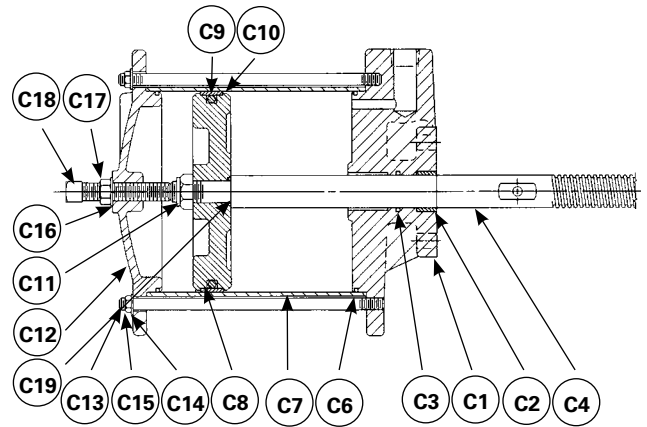



# Cylinder Actuators

## Water Hydraulic Cylinder Materials of Construction

Item	Description	Standard Construction	C-540 Construction
C1	Cylinder Head	Cast Iron, ASTM A126	Ductile Iron, ASTM A536 65-45-12 Nickel Plated
C2	Bearing	-	Bronze Oil Impregnated
C3	Rod Seal	-	Teflon with NBR
C4	Piston Rod	Stainless Steel, ASTM A564, Type 17-4	Stainless Steel, Type 304 Chrome Plated
C5	Vent Plug	-	Alemite 47200
C6	O-Ring	Acrylonitrile-Butadiene	Acrylonitrile-Butadiene
C7	Cylinder Tube	Fiberglass	Fiberglass
C8	Piston	Cast Iron, ASTM A126	Cast Iron, ASTM A126 Class B Nickel Plated
C9	O-Ring	Acrylonitrile-Butadiene	Acrylonitrile-Butadiene
C10	Piston Seal	Virgin Teflon	Virgin Teflon
C11	Nut	Stainless Steel, Type 18-8	Stainless Steel, Type 18-8
C12	Cylinder Cap	Ductile Iron, ASTM A536	Ductile Iron, ASTM A536 65-45-12 Nickel Plated
C13	Tie Rod	Zinc Plated Steel	Steel, AISI C1018 Zinc Plated
C14	Washer	Zinc Plated Steel	Zinc Plated Steel
C15	Nut	Zinc Plated Steel	Zinc Plated Steel
C16	Seal Thread	Steel with Nitrile	Steel with Nitrile
C17	Jam Nut	Zinc Plated Steel	Zinc Plated Steel
C18	Set Screw	Stainless Steel, Type 18-8	Stainless Steel, Type 18-8
C19	O-Ring	Acrylonitrile-Butadiene	Acrylonitrile-Butadiene
C25	Gland	Cast Iron, ASTM A126	-
C29	Scraper	Carbon Steel	-
C30	Packing	Neoprene & Cotton Duck	-

### Water Hydraulic — Standard

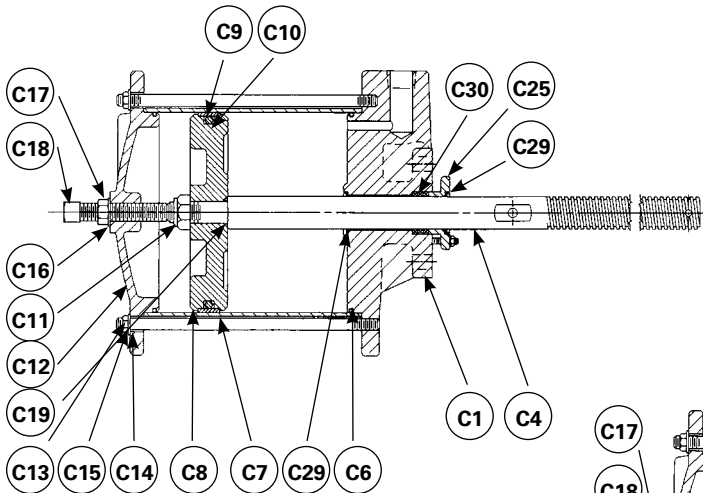

### Water Hydraulic — C-540

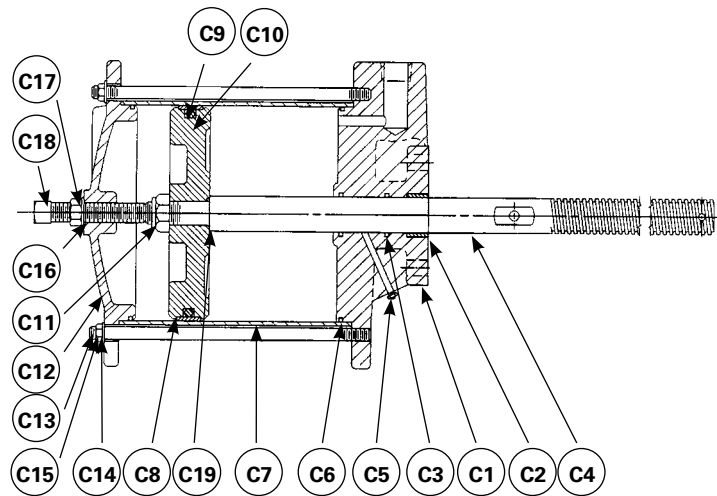

# Cylinder Actuator Accessories

## Positioners

DeZURIK offers both pneumatic and electronic signal valve positioners for use with cylinder actuators.

## Gauges

Pneumatic positioners are available with three gauges mounted and piped; electronic positioners are available with two gauges mounted and piped.

## 4-Way Solenoid Valves

For cylinder actuators, 4-way direct acting, two position solenoid valves feature metal enclosures, .25" (6mm) NPT connections, Cv of .70 and a maximum pressure differential of 125 psi (8.5 Bar). Solenoid coil voltage is both 110/50/1 and 120/60/1 AC power. Contact Sartell Valves, Inc. for DC voltage. Solenoids are available with or without manual overrides. On large valves, furnish valve/actuator size, service conditions, and required operating speed for recommendations. Solenoid action should be specified.

## Air Filter Regulator

For use on all pneumatic actuators. Includes a pressure reducing valve with filter and gauge. Maximum supply is 100 psi (7 Bar).

## Speed Control Valves

Speed control valves are available for controlling opening and closing speed on cylinder actuators.

## Position Indicating Switches

Available in NEMA 4, 4x, 7 or 9 ratings. Switches are available as two SPDT or four SPDT.

## Floorstand

For valves with cylinder actuators mounted on floorstand. Included with the floorstand are couplings, the extension pipe and mounting of the actuator on the floorstand.

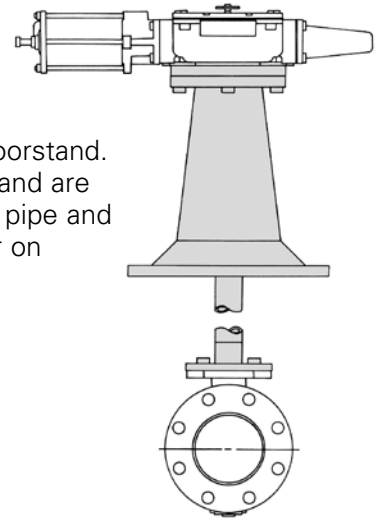

## Neck Extension

For 3–20" (80–500mm) valves using T-Series Cylinder actuators. Included is the extended valve neck and shaft with actuator mounted.

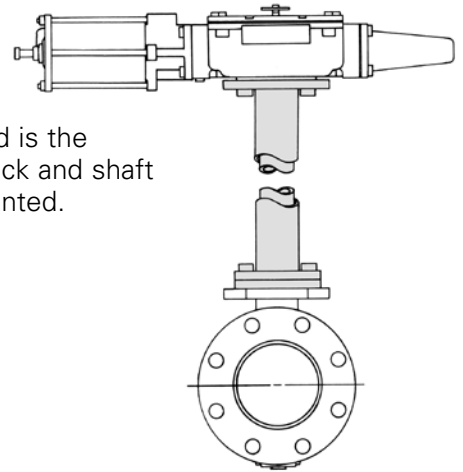

# Dimensions

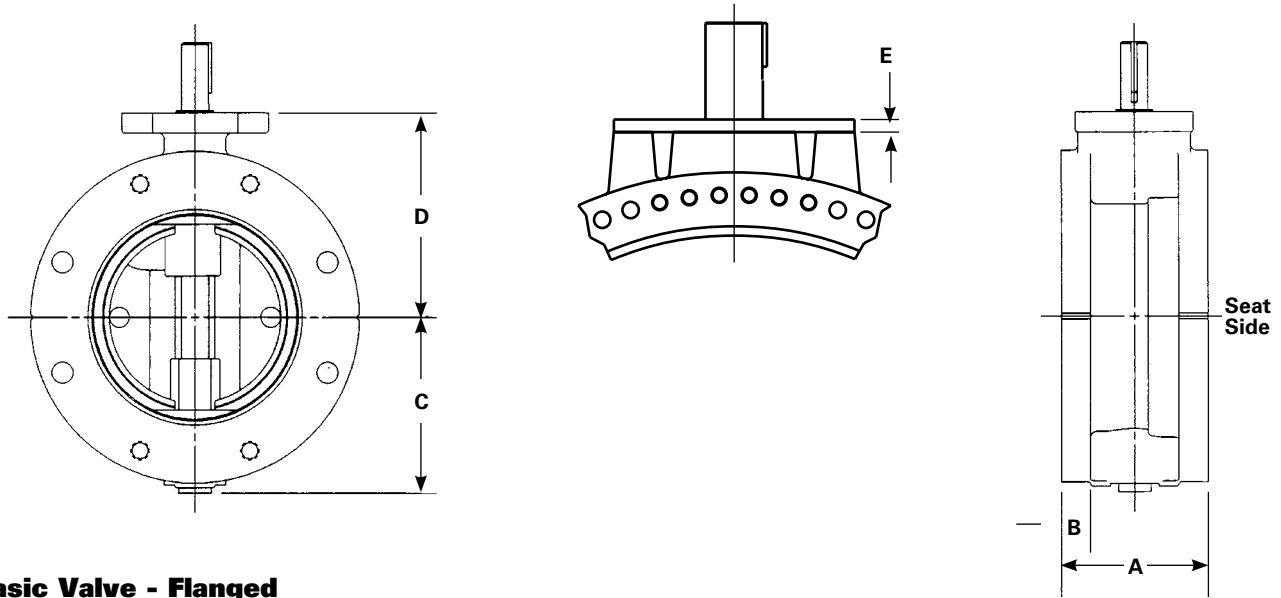

## Basic Valve - Flanged

Valve Size	A		B		C		D		E
	F1 25A, 75B & 150B	F2 250B	25A, 75B & 150B	250B	25A, 75B & 150B	250B	25A, 75B & 150B	250B	250B Only
3" 80mm	5.00 127	5.00 127	.81 21	1.19 30	4.00 102	4.12 105	4.81 122	4.81 122	-
4" 100mm	5.00 127	5.00 127	1.00 25	1.31 33	4.75 121	5.00 127	5.56 141	5.56 141	-
6" 150mm	5.00 127	5.00 127	1.06 27	1.50 38	6.03 153	6.25 159	7.00 178	7.00 178	-
8" 200mm	6.00 152	6.00 152	1.19 30	1.69 43	7.16 182	7.50 191	8.31 211	8.31 211	-
10" 250mm	8.00 203	8.00 203	1.25 32	1.97 50	8.38 213	8.75 222	9.50 241	9.50 241	-
12" 300mm	8.00 203	8.00 203	1.31 33	2.09 53	9.66 245	10.25 260	11.00 279	11.00 279	-
14" 350mm	8.00 203	8.00 203	1.47 37	2.25 57	10.91 277	11.50 292	11.50 292	11.50 292	-
16" 400mm	8.00 203	8.00 203	1.53 39	2.38 60	12.06 306	12.75 324	12.75 324	12.75 324	-
18" 450mm	8.00 203	8.00 203	1.66 42	2.50 64	14.03 356	14.50 368	13.50 343	14.00 356	-
20" 500mm	8.00 203	8.00 203	1.78 45	2.63 67	15.02 382	17.50 445	15.25 387	15.25 387	-
24" 600mm	8.00 203	12.00 305	1.97 50	2.91 74	19.00 483	20.19 513	18.41 468	19.50 495	-
30" 750mm	12.00 305	12.00 305	2.25 57	3.13 80	23.00 584	23.75 603	22.62 575	21.75 552	1.25 32
36" 900mm	12.00 305	15.00 381	2.50 64	3.50 89	27.38 696	27.38 695	25.62 651	25.62 651	1.25 32
42" 1100mm	12.00 305	15.00 381	2.75 70	3.81 97	30.91 785	30.91 785	30.42 773	30.42 773	1.25 32
48" 1200mm	15.00 381	15.00 381	2.88 73	4.13 105	35.38 899	35.38 899	33.00 838	33.00 838	1.25 32

Inches  
Millimeter

Contact DeZURIK for dimensions on valve sizes 54" (1400mm) and larger.

**Note:** All dimensions are subject to change without notice. Request certified drawings for use in preparing piping layouts.

# Dimensions

## Basic Valve — Mechanical Joint

Valve Size	A	B	C	D	E
4" 100mm	8.56 217	4.75 121	4.75 121	5.56 141	2.50 64
6" 150mm	8.88 226	4.75 121	6.03 153	7.00 178	2.50 64
8" 200mm	9.50 241	5.00 127	7.16 182	8.31 211	2.50 64
10" 250mm	9.88 251	5.25 133	8.38 213	9.50 241	2.50 64
12" 300mm	10.00 254	5.38 137	9.66 245	11.00 279	2.50 64
14" 350mm	12.38 315	6.62 168	10.91 277	11.50 292	3.50 89
16" 400mm	12.75 324	6.75 171	12.06 306	12.75 324	3.50 89
18" 450mm	13.42 341	7.00 178	14.03 356	13.50 343	3.50 89
20" 500mm	13.38 340	7.12 181	15.02 382	15.25 387	3.50 89
24" 600mm	13.75 349	7.50 191	19.00 483	18.41 468	3.50 89
30" 750mm	17.75 451	9.62 244	23.00 584	22.62 575	4.00 102
36" 900mm	18.00 458	10.00 254	27.38 696	25.62 651	4.00 102
42" 1100mm	18.75 476	10.25 260	30.91 785	30.41 772	4.00 102
48" 1200mm	19.62 498	10.62 270	35.38 898	33.00 838	4.00 102

Inches  
Millimeter

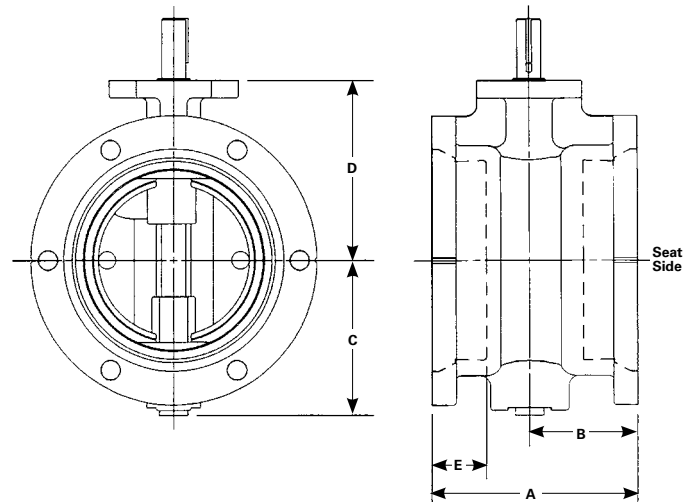

**Note:** All dimensions are subject to change without notice. Request certified drawings for use in preparing piping layouts.

## Lever Actuator

Valve Size	Dimensions			
	M	N	P	R
3-4" 80-100mm	2.56 65	3.56 90	3.00 76	14.00 356
6-8" 150-200mm	2.88 73	3.56 90	3.00 76	14.00 356

Inches  
Millimeter

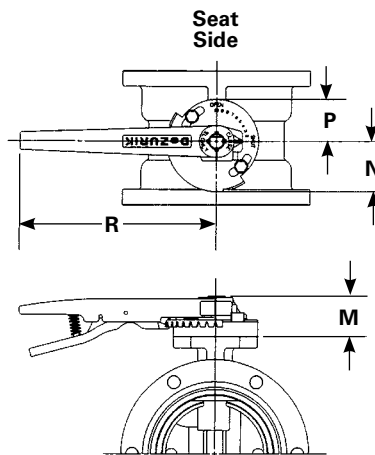

## GS/GB Nut

Valve Size	Actuator Size	Dimensions				
		M	N	O	P	Q
3-12" 50-300mm	6B	4.96 126	15.25 387	3.75 95	5.19 132	5.10 130
14-20" 350-500mm	6B	5.96 151	15.25 387	3.75 95	5.19 132	5.10 130
20-30" 500-750mm	12A	6.27 159	17.85 453	7.47 190	8.90 226	7.60 193

Inches  
Millimeter

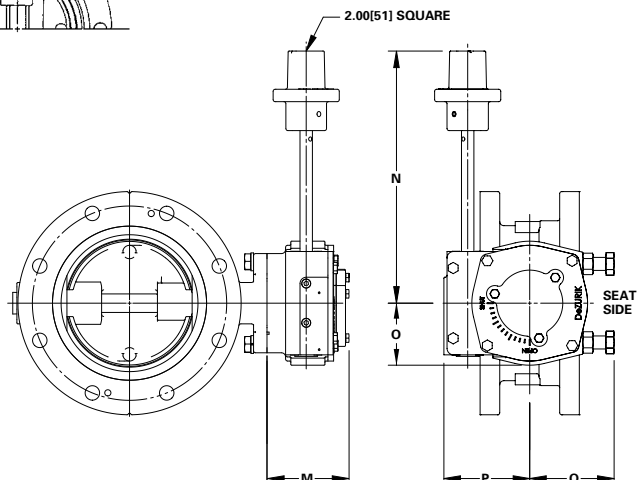

# Dimensions (continued)

## GS/GB Handwheel

Valve Size	Actuator Size	Dimensions					
		M	N	O	P	Q	R
3-12" 50-300mm	6B-HD8	4.54 115	11.81 300	3.75 95	5.19 132	5.10 130	8.00 203
	6B-HD12	4.54 115	11.81 300	3.75 95	5.19 132	5.10 130	12.00 305
	6B-HD16	4.54 115	12.25 311	3.75 95	5.19 132	5.10 130	16.00 406
14-20" 350-500mm	6B-HD12	5.54 141	11.81 300	3.75 95	5.19 132	5.10 130	12.00 305
	6B-HD16	5.54 141	12.25 311	3.75 95	5.19 132	5.10 130	16.00 406
	6B-HD24	5.54 141	15.94 405	3.75 95	5.19 132	5.10 130	24.00 610
18-20" 450-500mm	12A-HD16	5.66 144	15.48 393	7.47 190	8.90 226	7.60 193	16.00 406
	12A-HD20	5.66 144	15.48 393	7.47 190	8.90 226	7.60 193	20.00 508
24" 500mm	12A-HD12	5.68 144	15.12 384	7.47 190	8.90 226	7.60 193	12.00 305
	12A-HD16	5.68 144	15.48 393	7.47 190	8.90 226	7.60 193	16.00 406
	12A-HD20	5.68 144	15.48 393	7.47 190	8.90 226	7.60 193	20.00 508
	12A-HD24	5.68 144	19.19 487	7.47 190	8.90 226	7.60 193	24.00 610
	12A-HD30	5.68 144	20.69 526	7.47 190	8.90 226	7.60 193	30.00 762
28-30" 700-750mm	12A-HD20	5.68 144	15.48 393	8.25 210	8.90 226	7.60 193	20.00 508
	12A-HD30	5.68 144	20.69 526	8.25 210	8.90 226	7.60 193	30.00 762
	12A-HD36	5.68 144	22.75 578	8.25 210	8.90 226	7.60 193	36.00 914

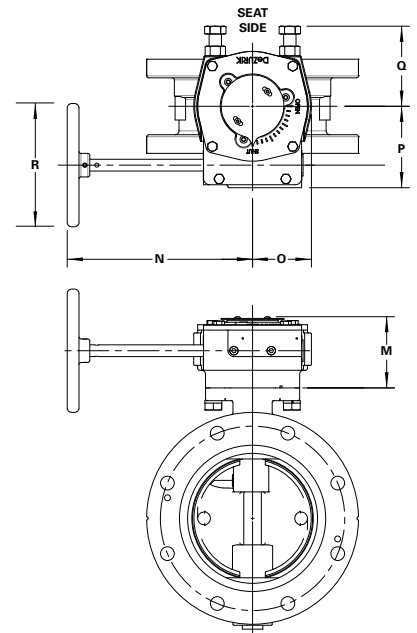

## GS/GB Chainwheel

Valve Size	Actuator Size	Dimensions					
		M	N	O	P	Q	R
3-12" 50-300mm	6B-CW8	4.54 115	11.81 300	3.75 95	5.19 132	5.10 130	8.00 203
	6B-CW12	4.54 115	11.81 300	3.75 95	5.19 132	5.10 130	12.00 305
	6B-CW20	4.54 115	18.64 473	3.75 95	5.19 132	5.10 130	20.00 508
14-20" 350-500mm	6B-CW12	5.54 141	11.81 299	3.75 95	5.19 132	5.10 130	12.00 305
	6B-CW20	5.54 141	18.64 473	3.75 95	5.19 132	5.10 130	20.00 508
	6B-CW24	5.54 141	18.64 473	3.75 95	5.19 132	5.10 130	24.00 610

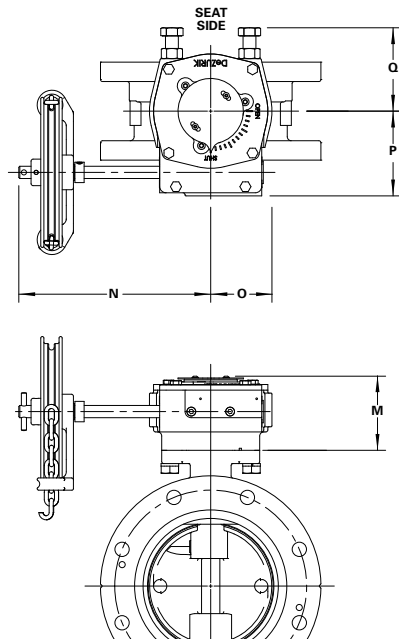



# Dimensions (continued)

## T-Series Cylinder Actuator

Valve Size (Cylinder Size)	F		G	H	I	J	K	L
	Pneumatic	Hydraulic						
3-12" 80-300mm (C4)	18.12 460	21.12 536	16.31 414	3.25 83	5.94 151	5.38 137	1.81 46	4.69 119
12" 300mm (C6)	18.88 480	21.88 556	16.31 414	3.25 83	5.94 151	7.88 200	1.81 46	4.69 119
14-16" 350-400mm (C6)	23.44 595	26.44 672	17.88 454	4.44 113	8.12 206	7.88 200	3.12 79	5.84 148
18-20" 450-500mm (C6)	23.44 595	26.44 672	17.88 454	4.44 113	8.12 206	7.88 200	3.12 79	6.03 153
18-20" 450-500mm (C8)	24.06 611	27.06 687	17.88 454	4.44 113	8.12 206	10.25 260	3.12 79	6.03 153

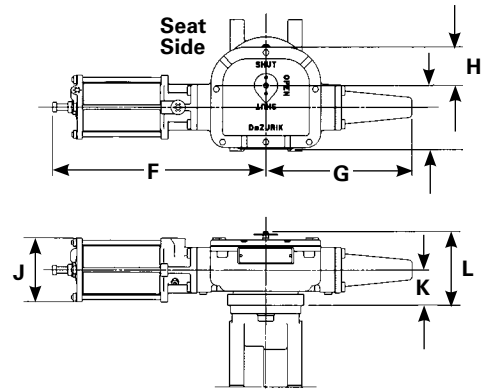

## G-Series Cylinder Actuator

Valve Size (Cylinder Size)	F		G	H	I	J	K
	Pneumatic	Hydraulic					
24" 600mm (GS-12-PC8)	31.50 800	32.75 832	17.50 445	6.88 175	4.25 108	8.50 216	3.25 83
24" 600mm (GS-12-PC10)	31.62 803	33.88 861	17.50 445	6.88 175	5.25 133	10.50 267	3.25 83
24" 600mm (GS-16-PC10)	43.88 1115	41.78 1061	24.25 616	9.00 229	5.88 149	11.75 298	3.50 89
30" 750mm (GS-12-PC8)	31.50 800	32.75 832	17.50 445	6.88 175	4.25 108	8.50 216	3.50 89
30-36" 750-900mm (GS-12-PC10)	31.62 803	33.88 861	17.50 445	6.88 175	5.25 133	10.50 267	3.50 89
30-42" 750-1100mm (GS-16-PC10)	43.25 1099	41.78 1061	24.25 616	9.00 229	5.88 149	11.75 298	3.75 95
36-42" 900-1100mm (GS-16-PC12)	44.62 1133	43.50 1105	24.25 616	9.00 229	7.00 178	14.00 356	3.75 95

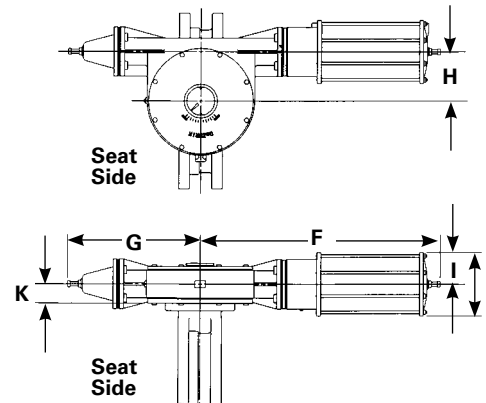

## LA-Series Nut

Valve Size (Actuator Size)	F	F with Spur Gear	G	H	I	J	K	L
30-42" 750-1100mm (LA-4)	14.19 360	20.81 529	9.38 238	8.25 210	9.44 240	2.00 51	4.41 112	6.25 159
36-54" 900-1400mm (LA-6)	16.19 411	22.81 579	12.12 308	8.25 210	11.12 282	2.00 51	4.41 112	6.25 159
42-54" 1100-1400mm (LA-10)	20.19 513	26.81 681	16.81 427	8.25 210	16.12 409	2.00 51	4.81 122	5.84 148

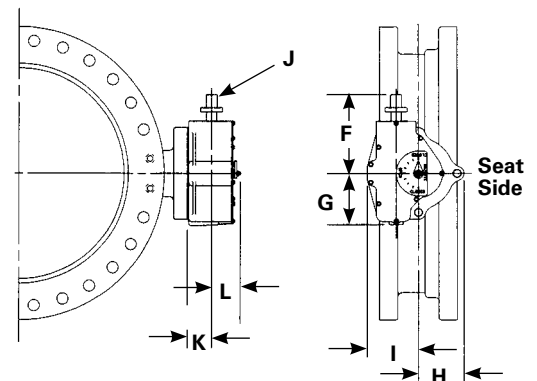

Inches  
Millimeter

# Dimensions (continued)

## LA-Series Handwheel 30-48" (750-1200mm)

Actuator Size	F	F with Spur Gear	G	H	I	J	K	L
LA-4-HD12	11.62 295	18.25 464	9.38 238	8.25 210	9.44 240	12.00 305	4.41 112	6.25 159
LA-4-HD16	12.25 311	18.88 480	9.38 238	8.25 210	9.44 240	16.00 406	4.41 112	6.25 159
LA-4-HD24	20.25 514	26.88 683	9.38 238	8.25 210	9.44 240	24.00 610	4.41 112	6.25 159
LA-4-HD30	22.88 581	29.50 749	9.38 238	8.25 210	9.44 240	30.00 762	4.41 112	6.25 159
LA-4-HD36	25.50 648	32.12 816	9.38 238	8.25 210	9.44 240	36.00 914	4.41 112	6.25 159

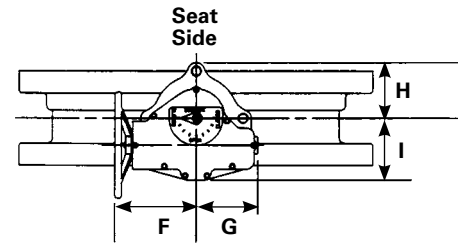

## LA-Series Handwheel 36-54" (900-1400mm)

Actuator Size	F	F with Spur Gear	G	H	I	J	K	L
LA-6-HD12	13.62 346	20.25 514	12.12 308	8.25 210	11.12 282	12.00 305	4.41 112	6.25 159
LA-6-HD16	14.25 362	20.88 530	12.12 308	8.25 210	11.12 282	16.00 406	4.41 112	6.25 159
LA-6-HD24	22.25 565	28.88 734	12.12 308	8.25 210	11.12 282	24.00 610	4.41 112	6.25 159
LA-6-HD30	24.88 632	31.50 800	12.12 308	8.25 210	11.12 282	30.00 762	4.41 112	6.25 159
LA-6-HD36	27.50 699	34.12 867	12.12 308	8.25 210	11.12 282	36.00 914	4.41 112	6.25 159

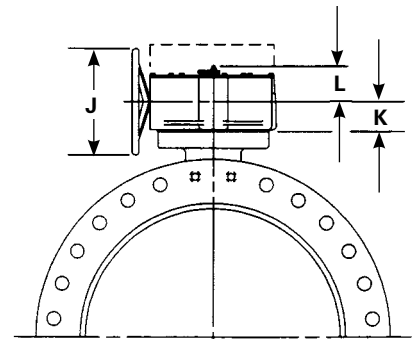

## LA-Series Handwheel 42-54" (1100-1400mm)

Actuator Size	F	F with Spur Gear	G	H	I	J	K	L
LA-10-HD12	17.62 448	24.25 616	16.81 427	8.25 210	16.12 409	12.00 305	4.81 122	5.84 148
LA-10-HD16	18.25 464	24.88 632	16.81 427	8.25 210	16.12 409	16.00 406	4.81 122	5.84 148
LA-10-HD24	26.25 667	32.88 835	16.81 427	8.25 210	16.12 409	24.00 610	4.81 122	5.84 148
LA-10-HD30	28.88 734	35.50 902	16.81 427	8.25 210	16.12 409	30.00 762	4.81 122	5.84 148
LA-10-HD36	31.50 800	38.12 968	16.81 427	8.25 210	16.12 409	36.00 914	4.81 122	5.84 148

Inches  
Millimeter

**Note:** All dimensions are subject to change without notice.  
Request certified drawings for use in preparing piping layouts.

# Dimensions (continued)

## LA-Series Chainwheel 30-48" (750-1200mm)

Actuator Size	F	F with Spur Gear	G	H	I	J	K	L
LA-4-CW12	35.00 889	41.62 1057	9.38 238	8.25 210	9.44 240	12.75 324	4.41 112	6.25 159
LA-4-CW20	35.00 889	41.62 1057	9.38 238	8.25 210	9.44 240	20.06 510	4.41 112	6.25 159
LA-4-CW30	35.00 889	41.62 1057	9.38 238	8.25 210	9.44 240	29.75 756	4.41 112	6.25 159

## LA-Series Chainwheel 36-54" (900-1400mm)

Actuator Size	F	F with Spur Gear	G	H	I	J	K	L
LA-6-CW12	37.00 940	43.62 1108	12.12 308	8.25 210	11.12 282	12.75 324	4.41 112	6.25 159
LA-6-CW20	37.00 940	43.62 1108	12.12 308	8.25 210	11.12 282	20.06 510	4.41 112	6.25 159
LA-6-CW30	37.00 940	43.62 1108	12.12 308	8.25 210	11.12 282	29.75 756	4.41 112	6.25 159

## LA-Series Chainwheel 42-54" (1100-1400mm)

Actuator Size	F	F with Spur Gear	G	H	I	J	K	L
LA-10-CW12	41.00 1041	47.62 1210	16.81 427	8.25 210	16.12 409	12.75 324	4.81 122	5.84 148
LA-10-CW20	41.00 1041	47.62 1210	16.81 427	8.25 210	16.12 409	20.06 510	4.81 122	5.84 148
LA-10-CW30	41.00 1041	47.62 1210	16.81 427	8.25 210	16.12 409	29.75 756	4.81 122	5.84 148

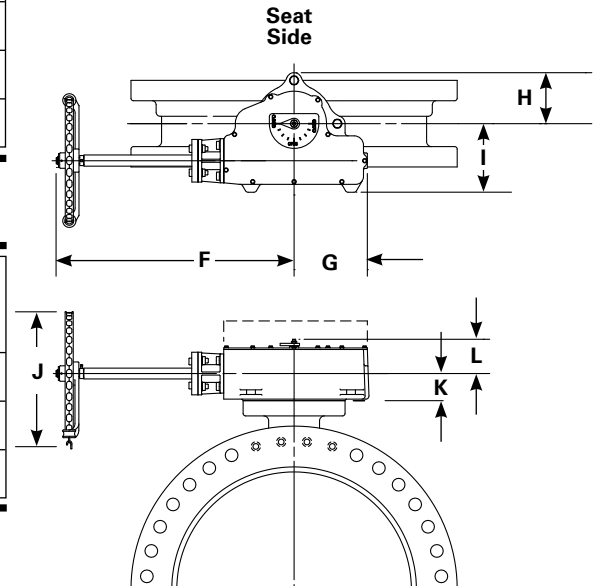

Inches  
Millimeter

**Note:** All dimensions are subject to change without notice.  
Request certified drawings for use in preparing piping layouts.

# DeZURIK Butterfly Valve Applications Data Input Checklist

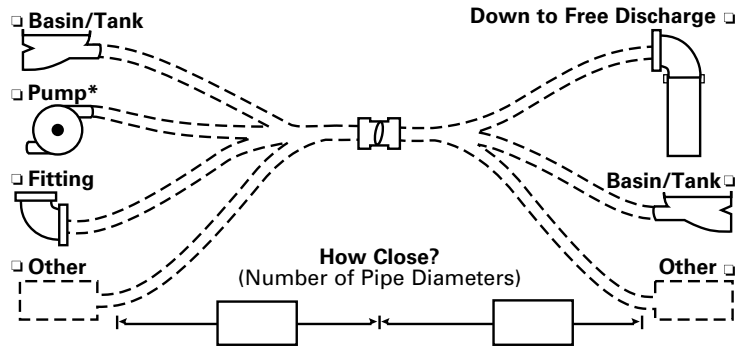

**Part A:** Check boxes and complete lines to show upstream/downstream configuration, enter distances in pipe diameters.

## Part B: Check off or enter operating conditions.

- Valve Function?  Open/Shut  Throttling  Modulating Control
- Where Installed?  Buried  Submerged  Above Ground, In Plant
- Line Fluid?  Fresh Water  Sewage  Air  Other? \_\_\_\_\_
- Maximum Fluid Temperature? \_\_\_\_\_°C \_\_\_\_\_°F
- Line Size? \_\_\_\_\_ inches \_\_\_\_\_(mm) (nominal)
- Normal Working Pressure? \_\_\_\_\_psi \_\_\_\_\_kPa  
Maximum (Shutoff) Pressure Differential? \_\_\_\_\_psi \_\_\_\_\_kPa
- Normal Wide Open Valve Flow? \_\_\_\_\_flow rate or \_\_\_\_\_flow units
- Emergency Maximum (Line Break, Etc.) Flow? \_\_\_\_\_flow rate \_\_\_\_\_flow units
- (If Throttling or Modulating Control) Flow Range Desired?  
Maximum Flow? \_\_\_\_\_flow rate \_\_\_\_\_flow units  
Minimum Flow? \_\_\_\_\_flow rate \_\_\_\_\_flow units
- Pipe Connection? \_\_\_\_\_Flanged \_\_\_\_\_Mechanical Joint \_\_\_\_\_Other

## Part C: Check off or enter operator requirements.

- Operator Type? Manual:  Lever  Lead Screw  Gear  Other?  
Power:  Cylinder  Electric  Other?
- Direction of Rotation To Open:  Clockwise—(OR)  Counter clockwise—(OL)
- Cylinder Specifications:
  - Supply Type and Pressure?  Water \_\_\_\_\_psi \_\_\_\_\_kPa  Oil \_\_\_\_\_psi \_\_\_\_\_kPa  
 Air \_\_\_\_\_psi \_\_\_\_\_kPa  Other \_\_\_\_\_psi \_\_\_\_\_kPa
  - Fail Safe?  Yes  No; If yes which way if valve fails?  Open  Close
  - Operating Times? \_\_\_\_\_sec Open to Close; \_\_\_\_\_sec Close to Open
  - Accessories?
 

<input type="checkbox"/> Speed Control	<input type="checkbox"/> Limit Switches (ES) (Qty: _____O, _____C, _____I)
<input type="checkbox"/> Solenoid W/Manual Override	<input type="checkbox"/> Positioner
<input type="checkbox"/> Manual Override (On loss of supply press.)	<input type="checkbox"/> Solenoid W/O Manual Override
<input type="checkbox"/> Other? _____	
- Electric Specifications:
  - Supply? \_\_\_\_\_Volts \_\_\_\_\_Phase \_\_\_\_\_Hz
  - Duty Cycle?  Intermittent  Continuous
  - Starter/Control Needs? \_\_\_\_\_
  - Operating Times? \_\_\_\_\_sec (Note: 60 sec per AWWA unless specified)
  - Accessories?
 

<input type="checkbox"/> AUX Switches	<input type="checkbox"/> Potentiometer	<input type="checkbox"/> Slidewire Receiver	<input type="checkbox"/> Reversing Starter
<input type="checkbox"/> Heaters	<input type="checkbox"/> Control Station	<input type="checkbox"/> Control Transformer	<input type="checkbox"/> Other? _____

## **Sales and Service**

For information about our worldwide locations, approvals, certifications and local representative:

Web Site: [www.dezurik.com](http://www.dezurik.com) E-Mail: [info@dezurik.com](mailto:info@dezurik.com)



250 Riverside Ave. N. Sartell, Minnesota 56377 • Phone: 320-259-2000 • Fax: 320-259-2227

*DeZURIK, Inc. reserves the right to incorporate our latest design and material changes without notice or obligation. Design features, materials of construction and dimensional data, as described in this bulletin, are provided for your information only and should not be relied upon unless confirmed in writing by DeZURIK, Inc. Certified drawings are available upon request.*